



DDMC802 Multipurpose Modular Controller

Control different load types with one device

The Philips Dynalite DDMC802 provides eight channels of control, with a maximum load per channel of 2A. The device is available with a variety of output modules to provide control of differing load types. The DDMC802 can be fully loaded to 16A.

- Single controller solution specifically suited to residential and hotel applications — Control a multitude of load types from one device.
- Trailing edge phase control dimmer module — Suitable for use with most types of dimmable electronic transformers.
- Leading edge phase control dimmer module — Suitable for use with incandescent lamps and some types of dimmable electronic transformers.
- HF driver control module — Suitable for controlling 0-10V and digital drivers and transformers. An additional relay control module is required to be paired when controlling 0-10V drivers.
- Relay control module — Suitable for controlling most types of switched loads.
- Fan control module — 400 VA fan control module.
- Curtain control module — Provides control of curtains, blinds and other window treatments.
- Flexible mounting solution — A DIN-rail mountable device, designed to be installed into the distribution board supplying power to the controlled circuit.

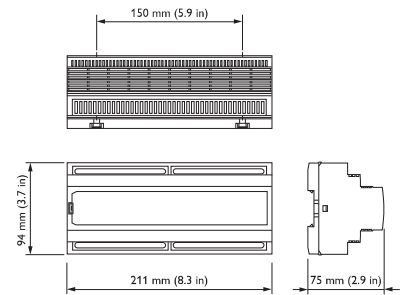

For detailed product information, please refer to the product information pages at www.philips.com/dynalite and follow the links.

Specifications

Due to continuous improvements and innovations, specifications may change without notice.

Item	Specification	Details
Electrical	Input Voltage	230 V ±14% 50 / 60 Hz Single Phase @ 16 A
	DyNet DC Supply	12 V @ 120 mA (supply for approx 6 user interfaces)
	Outputs	<p>8 x output slots @ 2 A each. Maximum device load 16 A. A derating factor may need to be applied if installed in a smaller sealed switchboard when using Leading or Trailing Edge dimmer modules. See Instruction Manual for details. Some modules occupy 2 slots. Available modules include:</p> <p>DDBM100: 1 channel; 1-10V or digital HF driver control. Occupies 1 slot</p> <p>DDBM101: 1 channel; 1-10V or digital HF driver control. For fittings that require full isolation from mains. Occupies 1 slot</p> <p>DDCM102: 1 channel 2 A SPDT curtain control. Occupies 2 slots</p> <p>DDFM102: 1 channel 400 VA fan control. Occupies 2 slots</p> <p>DDLMI02: 1 channel 2 A Leading Edge dimmer. Regulating device: Triac 20 A, 600 V. Occupies 1 slot</p> <p>DDLMI04: 1 channel 4 A Leading Edge dimmer. Regulating device: Triac 20 A, 600 V. Occupies 2 slots</p> <p>DDRM104: 1 channel 4 A relay. Switching device: Relay, 16 A / 250 V. Occupies 1 slot</p> <p>DDTM102: 1 channel 2 A Trailing Edge dimmer. Regulating device: Dual MOSFETs 22 A, 500 V, 88 A surge. Occupies 1 slot</p>
Power Conditioning	<p>Regulated outputs</p> <p>Over voltage protection</p> <p>Surge protection</p> <p>Brownout / Sag protection</p> <p>Spike protection</p> <p>Soft start</p> <p>16 bit fade resolution (65,536 steps)</p>	
Control	Control Inputs/Outputs	<p>One DMX512 / RS-485 DyNet serial port</p> <p>One programmable dry contact AUX input</p>
	User Controls	<p>Service switch</p> <p>Diagnostic LED</p>
	Preset Scenes	170
	Diagnostic Functions	<p>Circuit run time tracking on each channel</p> <p>Device online/offline status</p>
	Front Panel Controls (Optional -MO version only)	<p>Channel override switches</p> <p>Channel status indicators</p> <p>Service switch</p> <p>Service LED</p>
Physical	Supply Terminals	2 x 2.5mm ² or 1 x 4 mm ² conductor size Line, Neutral, Earth
	Output Terminals	Line, Neutral for each channel 2 x 2.5mm ² or 1 x 4 mm ² conductor size
	Dimensions (H x W x D)	94 mm x 211 mm x 75 mm (3.7" x 8.3" x 2.9")
	Packed Weight	0.94 kg
	Construction	Polycarbonate DIN-rail enclosure (12 unit)
	Operating Conditions	<p>Temperature: -0 to 40° C ambient</p> <p>Humidity: 0 to 95% non-condensing</p>
	Storage & Transport	<p>Temperature: -25 to 70° C ambient</p> <p>Humidity: 0 to 90% non-condensing</p>
Certification	Certification	CE, C-Tick
Options & Ordering	Standard Product	DDMC802 (Philips 12NC - 913703024009)
	Manual Override	DDMC802-MO (Philips 12NC - 913703024109)

Electrical Diagram

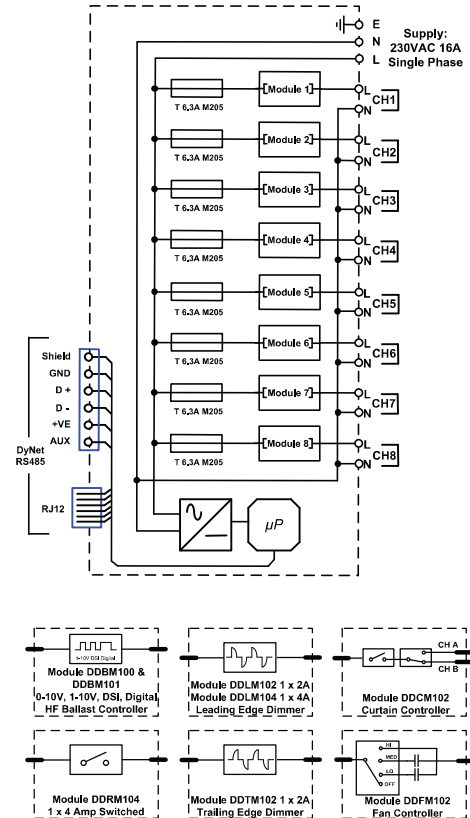

Philips Dynalite
6 / 691 Gardeners Road
Mascot, NSW 2020
Australia
Tel: +61 2 8338 9899
Email: dynalite.info@philips.com
Web: www.philips.com/dynalite



Specifications subject to change without notice. © WMGD Pty Ltd Trading as Dynalite. Unit 6, 691 Gardeners Road Mascot 2020 Australia. ABN 33 097 246 921. All rights reserved. Dynalite, DyNet and associated logos are the registered trademarks of WMGD Pty Ltd. Not to be reproduced without permission.