

Wallbox Power Module

HomeWorks® Wallbox Power Modules (WPM) control six zones of lighting. The WPM is designed to be located in closets, equipment rooms, and other locations in the home where it is “hidden” from view. Clients use keypads to control the lights connected to the WPM.

CONNECTION TO PROCESSOR

The WPM is wired like a six-zone GRAFIK Eye® control unit (GRX-3506). Each HomeWorks processor has three configurable links each capable of controlling up to eight WPM or GRAFIK Eye control units. This connection requires two pair [one pair 1.0mm² (#18 AWG), one pair 0.5-1.0mm² (#18-22 AWG) twisted shielded] Class 2/PELV wire. Lutron® wire model GRX-CBL-346S-500 may be used. The maximum cable length is 610m (2,000 feet), and this link must be wired in a daisy-chain configuration.

The wattage and load type specifications of the WPM are the same as six-zone GRAFIK Eye control unit (GRX-3106/3506 models). All connections on the back of the WPM are identical to those on the six-zone GRAFIK Eye control unit.

DEFAULT SCENE BUTTON

Each WPM has a default scene button on the front that allows a user to toggle between a preset scene and OFF. This scene is stored inside the WPM and can be activated at any time. The default scene provides “fail-safe” operation allowing the WPM to be controlled locally if communication to the processor is lost.

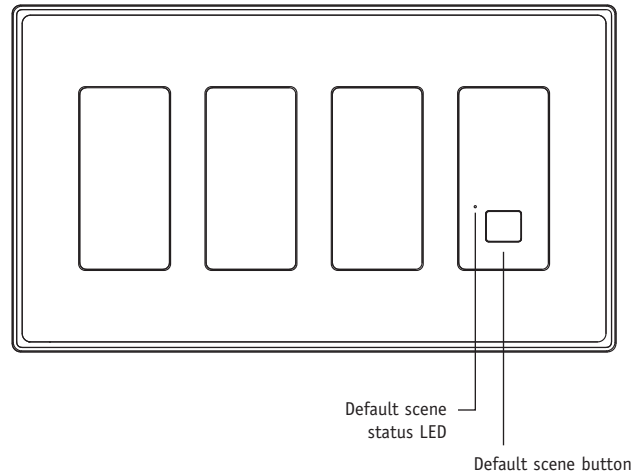

Wallbox Power Module

WPM BENEFITS:

- Minimises the number of controls on the wall
- Provides a cost-effective dimming solution to jobs with lower wattage loads
- Reduces overall job cost by up to 5-20% when less than 96 control zones are required
- Install in areas where available space is minimal
- Compatible with LINC™ prewire boxes

Note: Use 89mm (3-1/2 inches) deep wallboxes for ease of installation of GRAFIK Eye control units.

Wallbox Power Module

| Control Units | |
|----------------------------------|--|
| Model | HWI-WPM-6D-230CE: control six zones of lighting. (CE compliant) HWI-WPM-6D-240: control six zones of lighting. (non-CE) |
| Input voltage | 220-240VAC, 50/60Hz |
| Regulatory approvals | CE, C-Tick (CE compliant model) |
| Load types | Incandescent, magnetic low voltage, electronic low voltage (requires Lutron® low-voltage transformers), fluorescent non-dim, neon/cold cathode. The outputs are also compatible with <i>Lutron</i> Power Boosters and interfaces in <i>section 6</i> . |
| Maximum load (CE) | 2200W/VA per control unit, 800W/VA per zone. |
| Maximum load (non CE) | 3000W/VA per control unit, 1200W/VA per zone. |
| Minimum load | 25W/VA per zone. |
| Environment | Ambient temperature: 0-40°C, 32-104°F Ambient humidity: 0-90% humidity, non-condensing. Indoor use only. |
| Cooling method | Passive cooling. |
| Line-voltage connections | See <i>figure 3 and 4, page 4.12</i> . |
| Low-voltage wire type | Two pair [one pair 1.0mm ² (#18 AWG), one pair 0.5-1.0mm ² (#18-22 AWG) twisted shielded] Class 2/PELV wire. <i>Lutron</i> wire model GRX-CBL-346S-500 may be used. |
| Low-voltage wiring configuration | Maximum of 610m (2,000 feet) total. Must be wired in a daisy-chain configuration. See <i>figure 5, page 4.20</i> . |
| Low-voltage connection | One 4-pin removable terminal block. Each of the four terminals will accept up to two 1.0mm ² (#18 AWG) wires. Do not connect terminal 2 on processor communication link connector or between WPM units. |
| Addressing | Via rotary dial. Use 1 of 8 addresses on a GRAFIK Eye®/WPM link. |
| ESD protection | Meets or exceeds the IEC 61000-4-2 standard. |
| Surge protection | Meets or exceeds ANSI/IEEE standard c62.41. |
| Air gap | Provided when all circuits are off. |
| Power-failure memory | Non-volatile RAM. |
| Fail-safe operation | If communication with the processor is interrupted, all Wallbox Power Modules will still allow local control. |
| Dimensions | See <i>figures 1 and 2, page 4.19</i> . |
| Mounting | 4-gang US wallbox, 70mm (2-3/4 inches) deep minimum, 89mm (3-1/2 inches) deep recommended for ease of wiring. If mounting one control above another, leave at least 11.4cm (4-1/2 inches) vertical spacing between them. <i>Lutron</i> model 241400 may be used. |
| Shipping weight | 0.9kg (2 pounds) |

Wallbox Power Module

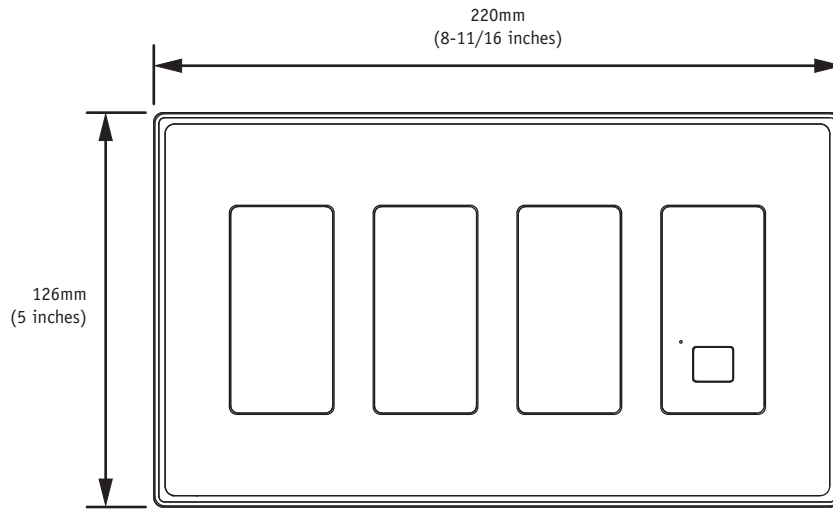

Figure 1 – front view

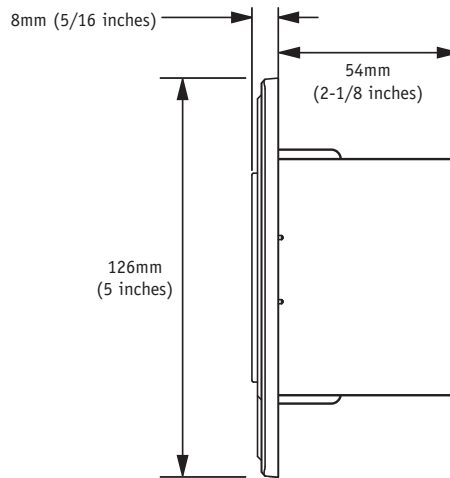

Figure 2 – side view

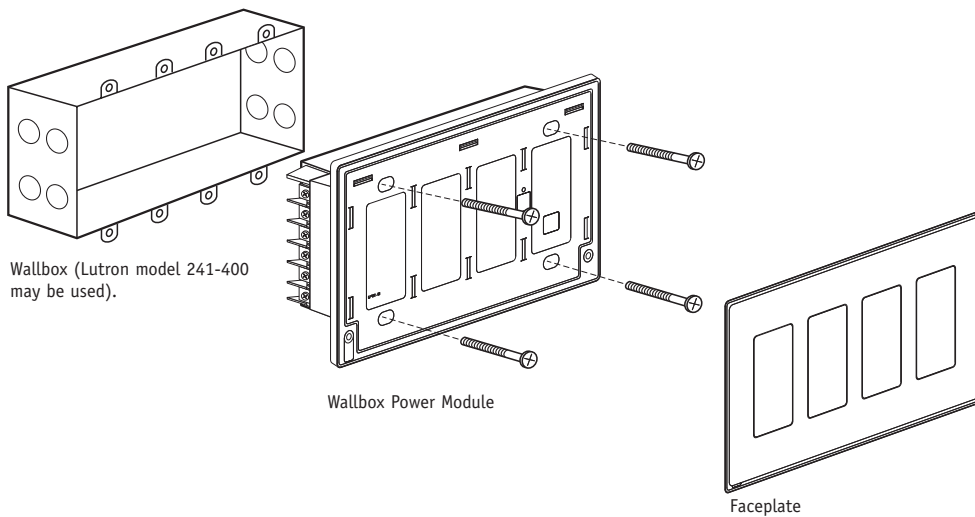

Figure 3 – mounting

Wallbox Power Module

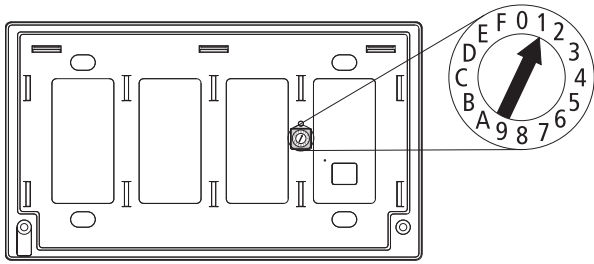
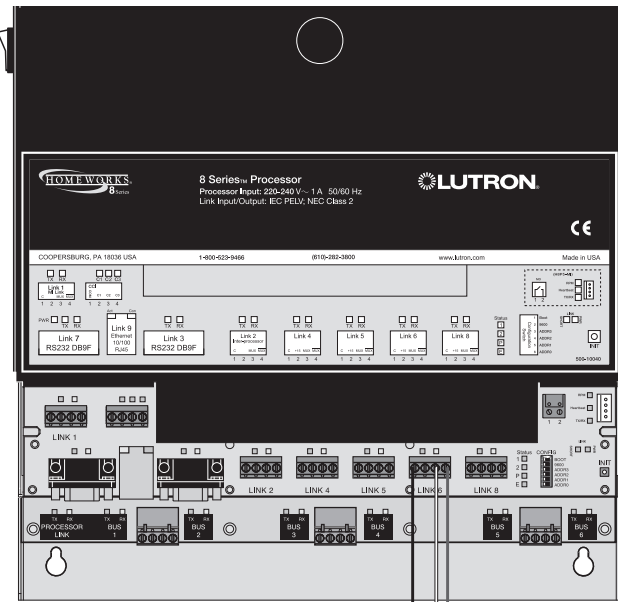

Figure 4 – rotary address switch location
(faceplate removed)

| Position | Proper module output/purpose |
|----------|----------------------------------|
| 0 | All outputs OFF |
| 1-8 | Address for normal operation |
| 9 | Output 1 full ON, all others OFF |
| A | Output 2 full ON, all others OFF |
| B | Output 3 full ON, all others OFF |
| C | Output 4 full ON, all others OFF |
| D | Output 5 full ON, all others OFF |
| E | Output 6 full ON, all others OFF |
| F | All outputs full ON |

Table 1 – rotary address dial operation



Pin 1 - One 1.0mm² (#18 AWG) for common
 Pin 2 - Do not connect
 Pins 3 and 4 - One pair 1.0-0.5mm² (#18-22 AWG) twisted/shielded for data

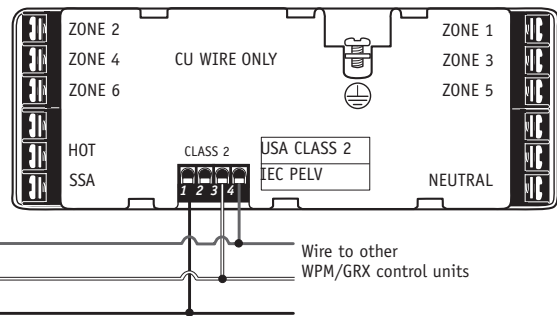

Figure 5 – connection to processor