



DMNG232 RS232 Network Gateway

Cost-effective serial port integration

The Philips Dynalite DMNG232 network gateway provides cost-effective serial port integration between a DyNet network and third-party systems.

- Seamless integration with third-party systems — Including AV systems, lighting desks, data projectors, HVAC, BMS and security systems.
- Internal controls — Including programmable logic controller capable of comprehensive conditional and sequential logic and arithmetic function processing.
- Utilize data format library or create your own — A library of data formats is available for systems integrators, or can be created using the onboard conditional logic engine to assemble and transmit user-defined data strings.
- Macro functions available — To simplify the control of multiple devices.
- Powered from the DyNet network — Requires no mains voltage supply.

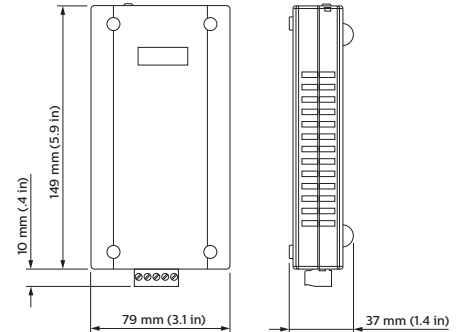

For detailed product information, please refer to the product information pages at www.philips.com/dynalite and follow the links.

Specifications

Due to continuous improvements and innovations, specifications may change without notice.

Item	Specification	Details
Electrical	Input Voltage	15 VDC supplied by the DyNet network @ 50 mA
Control	Control Ports	One RS-485 DyNet serial port One RS-232 serial port
	RS-485 Port Connections	SHLD, GND, D-, D+, +12V All available on screw terminals 1 x 2.5 mm ² max conductor size. Also available on RJ12 socket
	RS-232 Port Connections	Female DB9 connection
	RS-232 Port Modes	DTE, DCE; selected by jumpers
	RS232 Data Formats	Baudrate: 600 - 250 k Max packet length: 254 bytes Data bits: 7 / 8 Stop bits: 1 / 2 Parity: odd/even/none Flow control: none / RTS-CTS
	User Controls	Service Switch Diagnostic LED
	Internal Controls	Programmable Logic Controller
Physical	Dimensions (H x W x D)	37 mm x 79 mm x 149 mm (1.4" x 3.1" x 5.9")
	Packed Weight	0.15 kg
	Construction	ABS plastic
	Operating Conditions	Temperature: 0 to 50° C ambient Humidity: 0 to 95% non-condensing
	Storage & Transport	Temperature: -25 to 60° C ambient Humidity: 0 to 90% non-condensing
Certification	Certification	CE, C-Tick
Options & Ordeing	Standard Product	DMNG232 (Philips I2NC - 913703080309)

Electrical Diagram

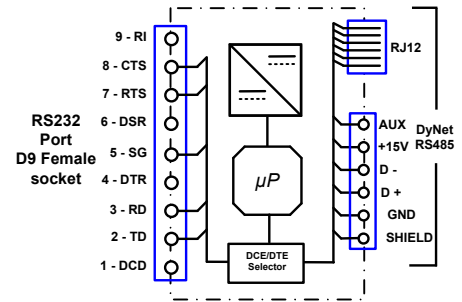

RS-232 Control Lines

Pin	Function	Implementation
1	DCD (data carrier detect)	Not conected
2	RD (received data)	Connected to UART
3	TD (transmitted data)	Connected to UART
4	DTR (data terminal ready)	Not conected
5	SG (signal ground)	Connected to Ground
6	DSR (data set ready)	Not connected
7	RTS (request to send)	Software controlled
8	CTS (clear to send)	Software controlled
9	RI (ring indicator)	Not connected



Philips Dynalite
6 / 691 Gardeners Road
Mascot, NSW 2020
Australia
Tel: +61 2 8338 9899
Email: dynalite.info@philips.com
Web: www.philips.com/dynalite

Specifications subject to change without notice. ©WMGD Pty Ltd Trading as Dynalite. Unit 6, 691 Gardeners Road Mascot 2020 Australia. ABN 33 097 246 921. All rights reserved. Dynalite, DyNet and associated logos are the registered trademarks of WMGD Pty Ltd. Not to be reproduced without permission.