



DTK622 Network Gateway

Passive network integration

The DTK622 is a network gateway that provides passive integration to a PC or RS232 system.

- Available in two formats — With either RS232 or USB connector.
- DTK622-232 provides full duplex integration to RS232 — Useful for linking the Philips Dynalite system with an AV or air conditioning system that supports RS232 communications.
- A DTK622-USB-J provides a useful interface between any PC and the Philips Dynalite system — Complete access to all network messages present on DyNet. To be used in conjunction with any of the Philips Dynalite software, this tool can be used to commission, diagnose/repair with EnvisionProject or used as a permanent gateway to the system for EnvisionManager head-end software.

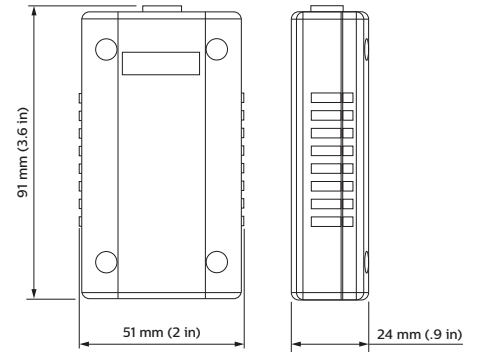

For detailed product information, please refer to the product information pages at www.philips.com/dynalite and follow the links.

Specifications

Due to continuous improvements and innovations, specifications may change without notice.

Item	Specification	Details
Physical	Connectors	DTK622-232 1 x D9 Female socket (RS232) 2 x RJ12 sockets (DyNet RS-485) DTK622-USB-J 1 x USB type B connector 2 x RJ12 sockets (DyNet RS-485)
	Dimensions (H x W x D)	24 mm x 51 mm x 91 mm (0.9" x 2.0" x 3.6")
	Packed Weight	0.94 kg
	Construction	ABS enclosure
	Operating Conditions	Temperature: 0 to 40° C ambient Humidity: 0 to 95% non-condensing
	Storage & Transport	Temperature: -25 to 60° C ambient Humidity: 0 to 90% non-condensing
Certification	Certification	CE, C-Tick
Options & Ordering	RS232 Version	DTK622-RS232 (Philips 12NC - 913703090109). Supplied with: One RS232 cable male to female connector, one RJ12 cable, one dings
	USB Version	DTK622-USB-J (Philips 12NC - 913703090209). Supplied with: One USB cable (type A to type B), one RJ12 cable, one dings



Electrical Diagram - DTK622-RS232

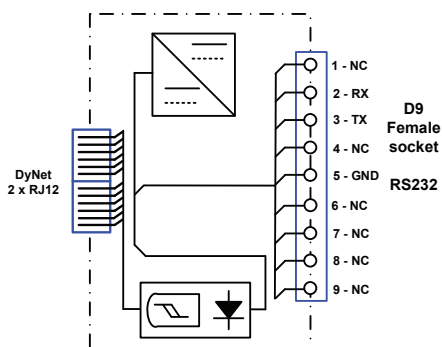

Electrical Diagram - DTK622-USB-J

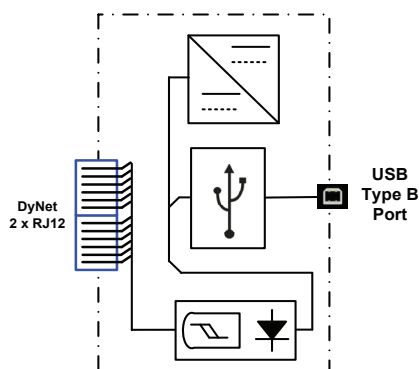

RJ12 6 Pole Wiring

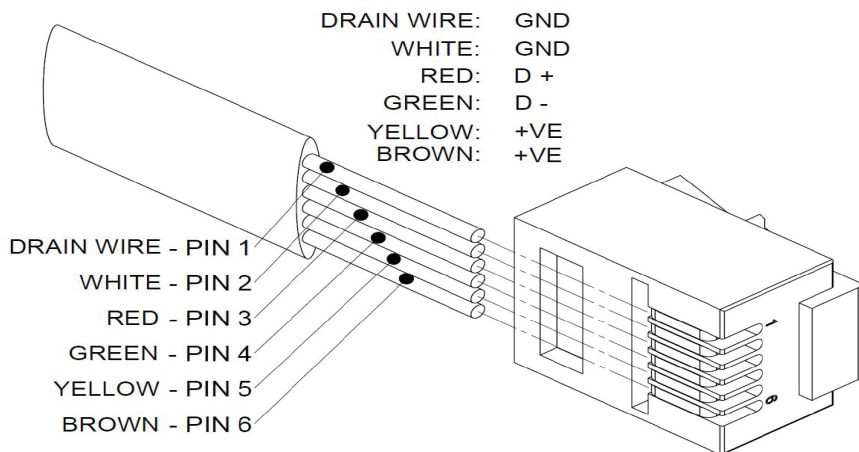

Philips Dyalite
 6 / 691 Gardeners Road
 Mascot, NSW 2020
 Australia
 Tel: +61 2 8338 9899
 Email: dyalite.info@philips.com
 Web: www.philips.com/dyalite

Specifications subject to change without notice. ©WMGD Pty Ltd Trading as Dyalite. Unit 6, 691 Gardeners Road Mascot 2020 Australia. ABN 33 097 246 921. All rights reserved. Dyalite, DyNet and associated logos are the registered trademarks of WMGD Pty Ltd. Not to be reproduced without permission.