

SCH1210

12 Channel x 10 Amp HF Ballast Source Controller

Key Features

- 120 Amp total box load on 12 circuits
- 1-10 volt, DSI and DALI ballasts
- 128 scene memory
- Multiple choice of circuit protection
- Security door for MCBs
- Optional RCBO per channel
- Fail to full safety feature
- iCAN network inputs
- Audio Visual Port (RS485)
- Panic/Fire alarm input
- Emergency Lighting Terminals
- Configuration stored in Non Volatile EEPROM
- Firmware storage in reflashable FLASH memory over iCAN network
- CE compliant to all relevant standards
- Designed and manufactured to ISO9001:2015 standards

Overview

This compact HF Ballast controller is a 12 channel device that provides 12 switched power circuits with 12 channels of scene set dimming for 1-10 volt, Tridonic DSI or DALI digital HF Fluorescent ballasts. Its 10 Amp power relays make it suitable for independent non-dimmable loads as well.

In addition to the iLight iCANnet™ network connectivity, it also has an audio visual port. It is suitable for controlling other 0-10 volt devices, such as a motorised Iris in a projector and 0-10 and DSI / DALI controlled transformers, and cold cathode. It is typically used on its own in medium to larger spaces that need manageable and controlled light, such as open plan offices, auditoria circulation lobbies, or as part of a comprehensive network in large building complexes.



Powering Business Worldwide

Mechanical

Weight: 9kg

Mains Cable Access:

12 x 25.5mm and 1 x 38mm knockouts

Control Cable Access: 1 x 25mm knockouts

Climate Range:

Temperature: +2°C to +40°C

Humidity: +5 to 95% non condensing

Control Inputs:

Two sets of terminals for the iCANnet™ network

One RJ12 socket for the programming iCANnet™ network
Suitable for Belden 1502

One set of terminals for the panic/fire alarm input

One set of terminals for the Audio Visual Port, RS485

Optional: DMX512 input card (add X to the end of the part number)

Dimensions

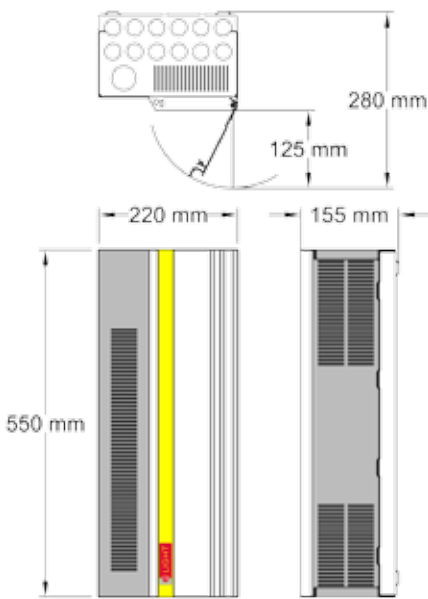

SCH1210 D version - 690x220x155mm.

RCBO & RCBOX version - 550x255x155mm

Electrical

Maximum Load: 40 Amp three phase @ 40°C

Maximum Channel Current: 10 Amp

Supply: 415/230 volts +/- 10% 50/60 Hz (optionally, 220/127 volt 60 Hz)

Protection: 10 amp MCBs Type C, 10KA rated

Options

SCH1210S - Single pole with isolator

SCH1210RCBO - RCBO Breakers with isolator

SCH1210RCBOX - 12 x SP MCBs with isolator (For field fit of RCBOs)

Load Types:

1-10 volts HF Fluorescent, 100 per channel, 1200 per unit.

Tridonic DSI HF Fluorescent Ballast, 64 per channel, 128 per unit.

Broadcast DALI HF Fluorescent Ballast, 64 per channel, 128 per unit.

0-10 volt Iris control (20K Ohm input)

1-10 volt Multi-Load transformers 1000 (Control only)

Dimmed Outputs:

12 x 1-10 volts at 0.1 Amp sink current per channel

12 x Tridonic DSI outputs (uses electronic power switching in ballasts)

12 x DALI outputs (uses electronic power switching in ballasts)

The output types above are selectable within iCANedit for each circuit

Switched Outputs:

12 x 230v 10 Amp (inductive or resistive)

Terminal Sizes:

Incoming supply, max' cable size: 10mm²

Ballast output, max' cable size: 12 pairs x 2.5mm²

Loads, max' cable size: 1 x 4mm² or 2 x 2.5mm² per circuit

iCANnet™ network cable size: 5 x 1mm²

Audio Visual Port: RS485 2 x 1mm²

Panic/fire alarm input: 2 x 1mm²

Memory:

FLASH memory to be able to upgrade firmware

EEPROM for 128 scene memory

Fade Times: 0.1 seconds to 60 minutes

Other HF Ballast Controllers: SCH0410, SCH1220, SCM0410 and the SCH1200T

Typical Schematic

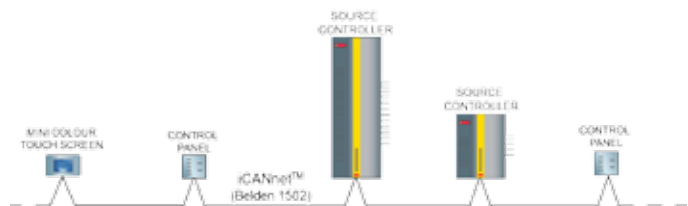

Contact your local Eaton office

T: +44 (0)1923 495495 F: +44 (0)1923 228796

E: enquiries@iLight.co.uk www.iLight.co.uk

Eaton Lighting Systems
20 Greenhill Crescent,
Watford Business Park,
Watford, Herts, WD18 8JA. UK
eatonlightingsystems.com

© 2018 Eaton
All Rights Reserved

Document No: SCH1210 Rev9 0318

Changes to the products, to the information contained in this document, and to prices are reserved; so are errors and omissions.

Eaton is a registered trademark.

All other trademarks are property of their respective owners.

EATON

Powering Business Worldwide

CE

