



PDEG

Ethernet Gateway

Flexible Ethernet integration

The Philips Dynalite PDEG provides a multipurpose Ethernet connection to a Philips lighting control system. It supports access to the lighting system via a dedicated Philips app as well as providing a web interface delivering access to the inbuilt timeclock and schedule editor functions. It provides bridging functionality between Ethernet backbone and the DyNet fieldbus devices.

PDEG

Flexible Ethernet integration

- **Large storage capacity** – The device stores large project files internally, which apps use to automatically configure their settings. This saves configuration time and ensures accuracy for phone and tablet control.
- **Built-in web server** – Provides control and status via Common Gateway Interface (CGI) protocol. Allows authenticated users to edit and check system settings via the Network Hardware Checker and System Roll Call tools.
- **Secure Access** – Employs HTTPS for secure, encrypted network communication.
- **Network routing** – Routing functionality such as address offset and message filtering and translation
- **Scheduled event management** – Inbuilt timeclock, schedule manager, sunrise/sunset tracking and automatic daylight saving adjustment allow the user to manage operation and task scheduling without advanced technical knowledge.
- **Powerful custom task engine** – Allows users or third-party systems to run macros, such as 'After Hours', 'Shut Down', 'Welcome' and more.
- **Advanced interoperability** – Supports management of Philips Dynalite systems, Philips PoE fittings, and Philips Hue lamps and bridges, on a single system.
- **Third party integration** – Capable of direct communication with specialized hospitality and building automation systems such as VingCard Elsafe, CoolAutomation, Oracle Fidelio, and others.
- **Day Rhythm*** – Supports up to five color temperature curves to simulate the intensity and color temperature of natural daylight over the course of a day. Different curves can be assigned to different seasons or specific days as required.

* Requires a DALI 209 compatible dimming controller.

Dimensions

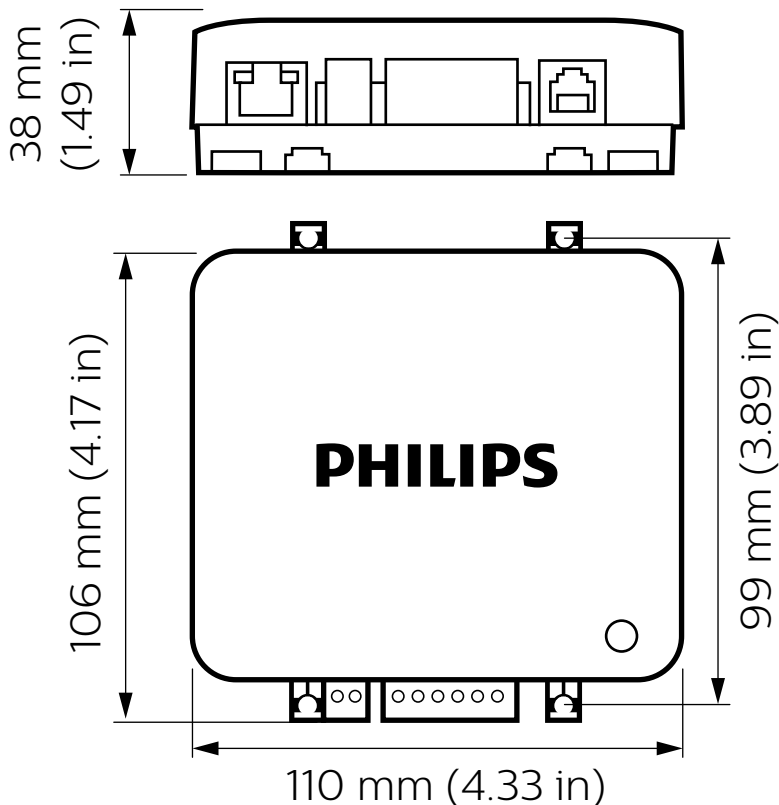

Specifications

Due to continuous improvements and innovations, specifications may change without notice.



PDEG Ethernet Gateway

Electrical

Supply Type	DyNet or DC*
Supply Voltage	12-24 VDC†
DyNet Supply Current	100 mA @ 12 VDC 50 mA @ 24 VDC
DC Supply Current	300 mA @ 12 VDC 250 mA @ 24 VDC
DyNet DC Output Current‡	200 mA
IEC Overvoltage Category	III

Control

Communication Ports	1 x RS-485 1 x Ethernet (10/100 baseT)
Supported Protocols	DyNet / DyNet2 DMX TCP/IP (TCP, UDP, IPv4/IPv6) HTTP / HTTPS / FTP / CGI / Telnet
Dry Contact Inputs	1 (AUX)
Clock Features	365 day clock Lithium backup battery Sunrise/sunset tracking Automatic daylight saving adjustment 250 timed events 64 tasks
Storage Capacity	16 MB XML file storage max (28-day rolling network log)
User Input	1 x service switch
Indicators	1 x service LED 2 x Ethernet status LED

Physical

Dimensions (H x W x D)	97 x 110 x 38 mm (3.82 x 4.33 x 1.50 in)
Packed Weight	0.21 kg (0.46 lb)
Construction	Low profile DIN-rail polycarbonate (6 unit)
Communication Ports	1 x RJ45 1 x RJ12 1 x 6-way pluggable screw terminal
Communication Terminal Conductor Size	2.5 mm² (#12 AWG) (max)
Supply Terminals	1 x 2-way pluggable screw terminal
Supply Terminal Conductor Size	2.5 mm² (#12 AWG) (max)

Environment

Operating Temperature	-20° to 50°C ambient (-4° to 122°F)
Storage/Transport Temperature	-25° to 70°C ambient (-13° to 158°F)
Relative Humidity	0 to 90% non-condensing
IEC Pollution Degree	II

Compliance

Certification	CE, RCM, UL/cUL, FCC, ICES, RoHS
---------------	----------------------------------

* From external regulated SELV / Class 2 supply
 † Power supply voltage shall match network voltage
 ‡ If powered by external SELV / Class 2 supply



Electrical

SELV/CLASS 2 external supply

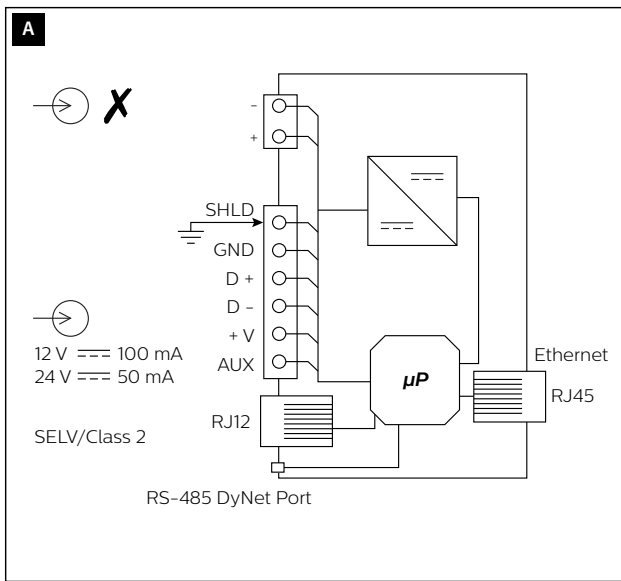

DyNet supply

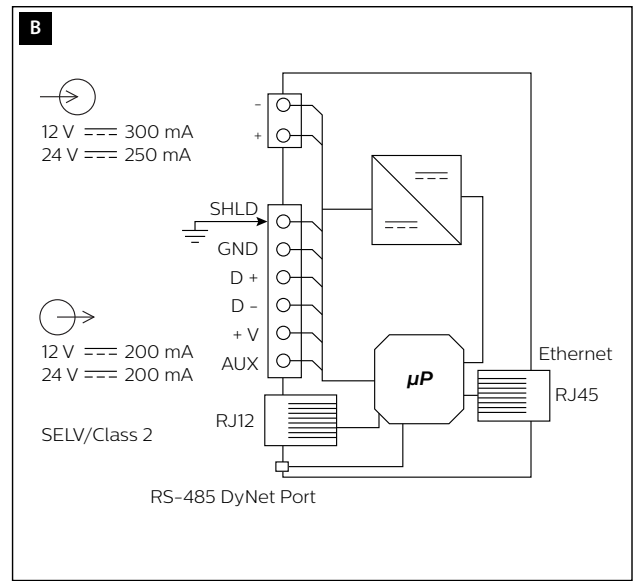

Ordering Code

Product

PDEG

Philips 12NC

913703013809

Accessories

DDNP1501

(12 VDC network power supply)

913703090309

DMNP24040-P-NA

(24 VDC network power supply)

913703580309



© 2018 Signify Holding. All rights reserved. Specifications are subject to change without notice. No representation or warranty as to the accuracy or completeness of the information included herein is given and any liability for any action in reliance thereon is disclaimed. Philips and the Philips Shield Emblem are registered trademarks of Koninklijke Philips N.V. All other trademarks are owned by Signify Holding or their respective owners.