

Power & Processor Unit 9 x 6A

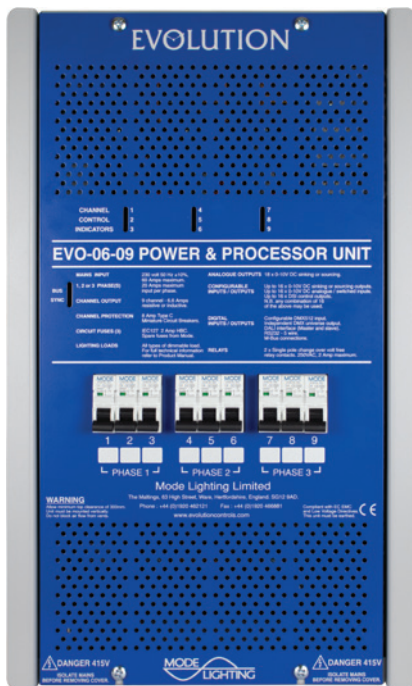

Evolution is a versatile and highly configurable architectural control system designed for both lighting and peripheral management.

Evolution is uniquely adaptable, making it an ideal choice for use in a vast number of applications including modern smart homes, shopping centres, restaurants, hotels, cruise ships, boardrooms, hospitality suites and offices. System features include RS-232, DMX, DSI and 0/1-10V controls.

A built in astronomical time clock facilitates events triggered at any time of day, linked with sunrise - sunset calculations or by user definable seasons. Any input may control any output with the ability to provide operation of a sequence of events, for example, control of lighting, blind motors, commands to building management systems, colour changing etc.

Key Features

- » Nine dimmable channels of 6.6A resistive or inductive loads, user selectable for dimming or switching.
- » Up to 1.5A of compatible LED load per channel.
- » Leading Edge Dimming Technology.
- » Fully configurable control operation.
- » Multi function DSI, DMX, M-BUS, RS-232, 0/1-10V and contact operation.
- » Astronomical time clock built in.
- » Intelligent self monitoring power supply.
- » Factory set default operation for quick installation and testing.
- » Individual 8A Type C MCB Circuit Protection.
- » Emergency Fixed Live MCB protected outputs (2 per phase) for maintained emergency supplies.
- » DIN rail mounted wiring terminals.
- » Supply input 230/240V. 50-60Hz. Single or three phase options.
- » Complies with EC EMC and Low Voltage Directives (CE).
- » 2 year warranty.

EVOLUTION
IT WAS ONLY A MATTER OF TIME



System Architecture

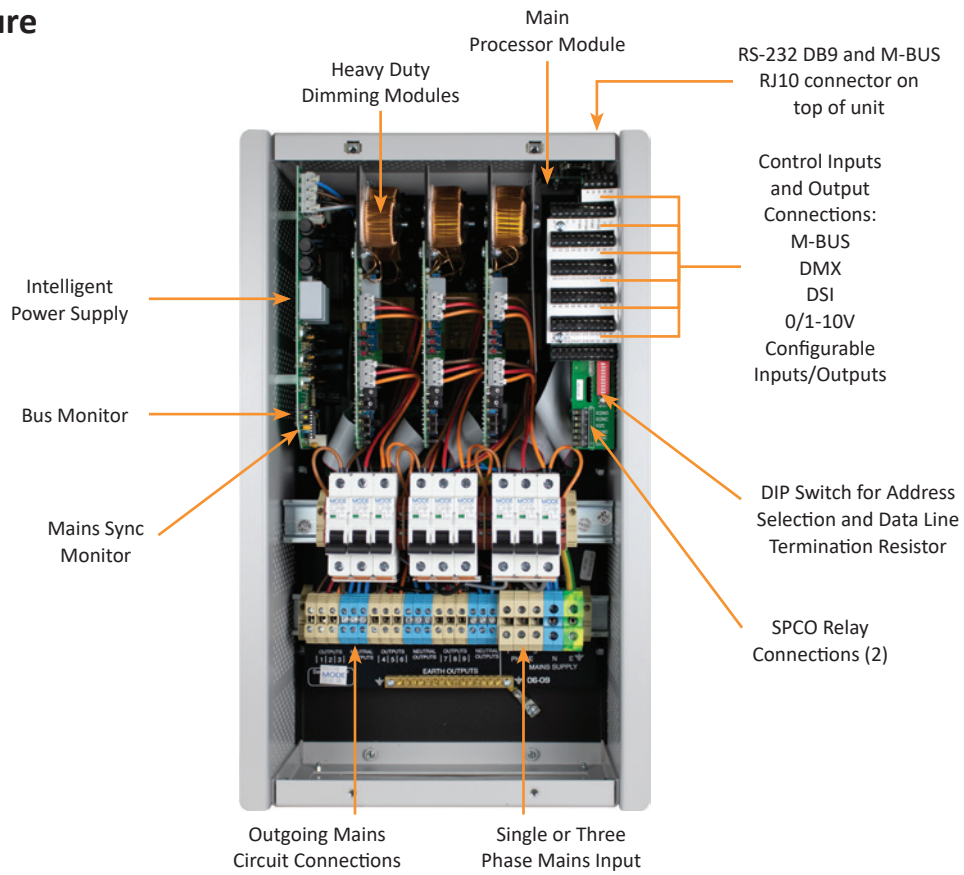

Technical Data

Power	
Mains Supply	» 230V AC +/- 10% 50/60Hz, single or three phase options
Control Fuse	» 20mm x 5mm 2A HRC ceramic (3)
Connections & Cable Specifications	
Channel Outputs	» Nine channels of 6.6A resistive or inductive loads » Up to 1.5A for LED loads depending on LED de-rating factor » Check with LED lamp manufacturer for recommended number of lamps on an 8A MCB or RCBO*
Output Type	» M-BUS, RS-232, DMX, 0/1-10V, DSI
Circuit Protection	» Individual Miniature Circuit Breaker (MCB) 8A Type C » RCBOs available to special order
Control Input	» M-BUS, RS-232, DMX, 0/1-10V, Contact Closure
Contact Output	» 2 x SPCO (250V AC, 2A maximum) relay contacts
Mechanical	
Standards	» EN55015, EN61547, EN61000-3-3, EN60439-1, EN60950
Conduit Entries	» Five off 32mm diameter or removable panel
Dimensions	» 534mm High x 322mm Wide x 160mm Deep
Fixing Centres	» 452mm x 302mm
Weight	» 11kgs
Packed Size	» 600mm High x 400mm Wide x 240mm Deep
Packed Weight	» 12kgs

Note

For additional technical information refer to Installation Guide EVO-06-09.

*The maximum number of lamps on a circuit and dimming performance will vary for different lamps and manufacturers. Users should verify performance and dimming range with the lamp manufacturer. For further advice please contact your local distributor or the Mode Lighting Technical team.

Installation should be in accordance with the relevant National Wiring Regulations and other applicable Regulations. Compliance to EC EMC and Low Voltage Directives may be invalidated if not used or installed according to the published specification.

EVO-06-09 should be located in well ventilated areas and should not be covered or enclosed by insulating materials.

Mode reserve the right to amend the product specification or design at any time and without notice.



Mode Lighting Limited. The Maltings, 63 High Street, Ware, Hertfordshire, SG12 9AD. United Kingdom.
Tel: +44 (0) 1920 462121 | Fax: +44 (0) 1920 466881 | Email: sales@modelight.com | www.modelight.com