

PRO LED+ Phase Adaptive Power Module

The Energi Savr Node (ESN) family is a group of modular products for the control of lighting loads and motor loads.

This document describes the following product:
 QSNE-4A5-230-D: 4-Zone ESN for phase control dimming of lighting loads

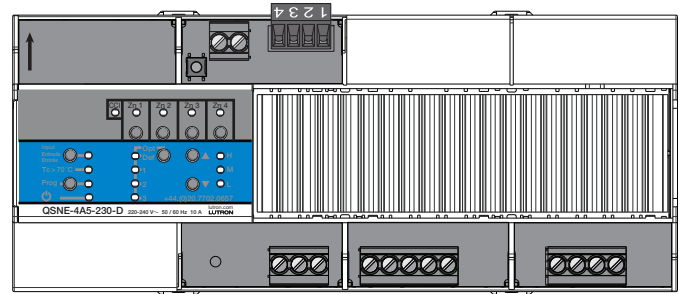

QSNE-4A5-230-D

Features

- PRO LED+ Phase Adaptive Power Modules can be used in a QS Standalone system with an iOS Energi Savr Application, a Quantum system, or an Athena system.
- Includes QS link for seamless integration of lights and controls.
- An auto-detect mode is available to detect and configure forward-phase or reverse-phase (leading-edge or trailing-edge) dimming for incandescent/halogen, electronic/magnetic low-voltage, and neon/cold cathode light sources.
- A locked forward-phase or reverse-phase (leading-edge or trailing-edge) mode is available.
- Controls dimmable LED loads. Refer to www.lutron.com/ledtool for compatibility with dimmable LED light sources.
- RTISS technology compensates for incoming mains voltage variations such as changes in Root Mean Square (RMS) voltage, frequency shifts (up to $\pm 2\%$ change in frequency/second), harmonics and line noise.
- RTISS-TE technology allows for true instantaneous voltage compensation for incoming mains voltage variations. Only operates in reverse-phase (trailing-edge) when "voltage-comp." is enabled in the design software.
- RTISS-ICM technology is able to withstand high-inrush LEDs, bulb blowouts, and direct shorts.
- Provides air gap off (when all zones are off).
- Integral protection for common temporary over-current and over-voltage conditions.
- LEDs on the module provide diagnostic information.
- Buttons on the module provide override control.
- Emergency contact closure input (CCI).
- Power failure memory automatically returns the outputs to the levels they were set to prior to a power outage.

Job Name: <input type="text"/>	Model Numbers: <input type="text"/>	
Job Number: <input type="text"/>	<input type="text"/>	<input type="text"/>

QS Standalone Example⁴

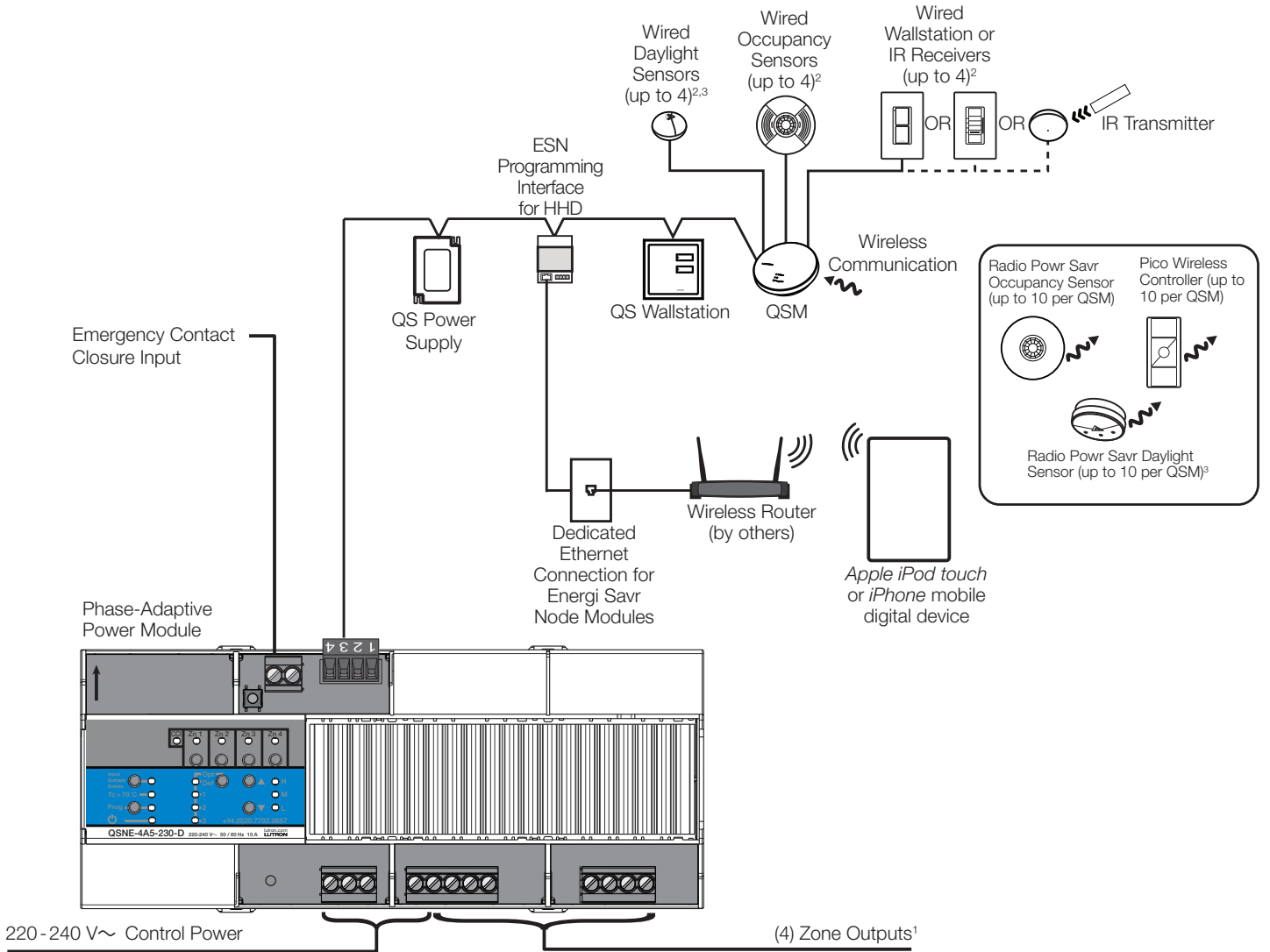

Notes:

- ¹ See "Output Zone Ratings" in "Specifications" section, for specific load types ratings.
- ² Up to 4 wired sensors or Pico wireless controllers total (of any type) per QSM.
- ³ The maximum number of daylight sensors (wired and wireless) that an ESN module can support is four (1 per zone).
- ⁴ Not all products shown are available in all regions.

Job Name: <input style="width: 90%; height: 20px;" type="text"/>	Model Numbers: <input style="width: 95%; height: 20px;" type="text"/>
Job Number: <input style="width: 90%; height: 20px;" type="text"/>	<input style="width: 95%; height: 20px;" type="text"/>

Athena/Quantum Example⁴

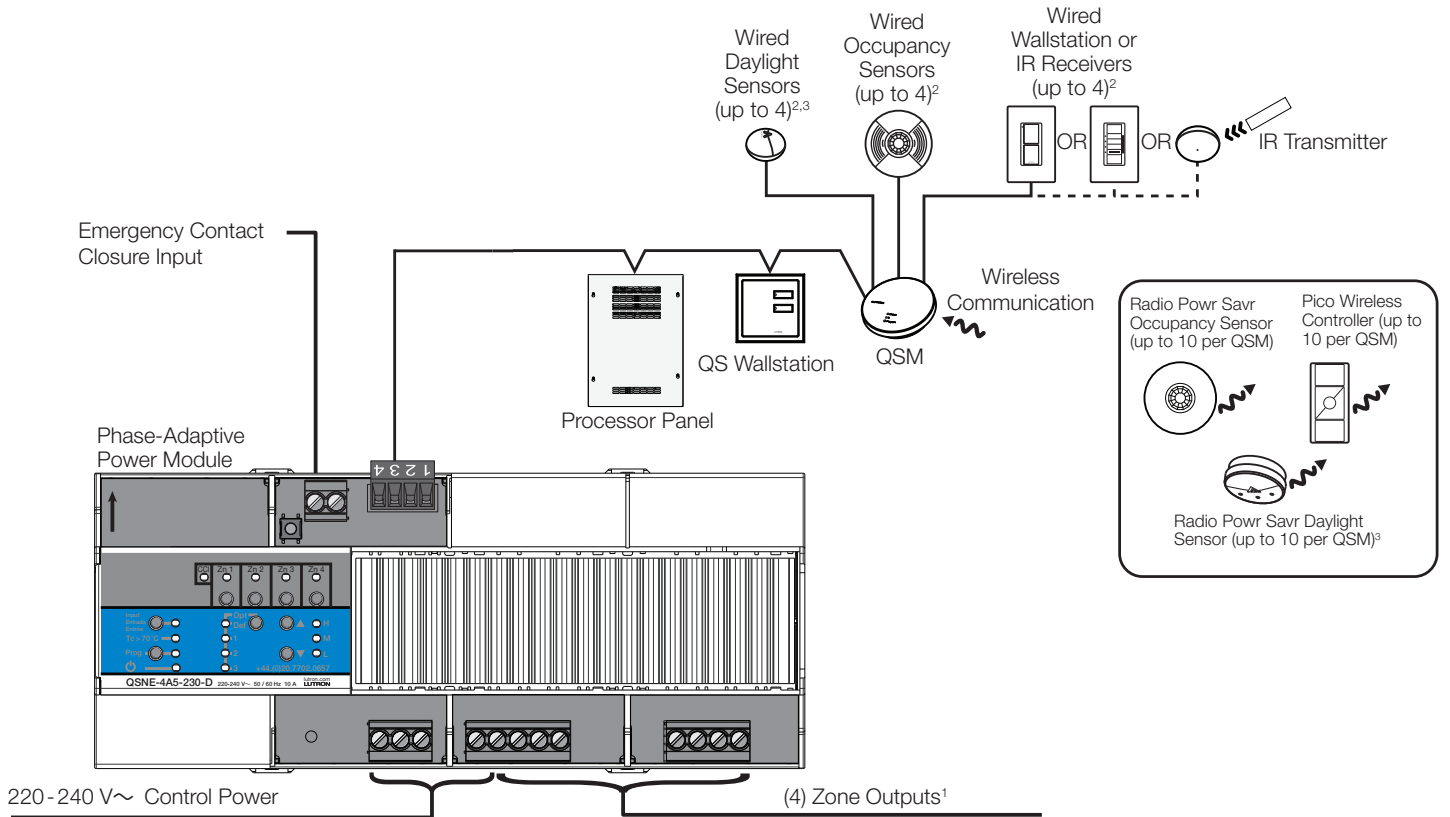

Notes:

- ¹ See "Output Zone Ratings" in "Specifications" section, for specific load types ratings.
- ² Up to 4 wired sensors or Pico wireless controllers total (of any type) per QSM.
- ³ The maximum number of daylight sensors (wired and wireless) that an ESN module can support is four (1 per zone).
- ⁴ Not all products shown are available in all regions.

Job Name: <input style="width: 90%; height: 20px;" type="text"/>	Model Numbers: <input style="width: 95%; height: 20px;" type="text"/>
Job Number: <input style="width: 80%; height: 20px;" type="text"/>	<input style="width: 95%; height: 20px;" type="text"/>

Specifications

Phase-Adaptive Power Module

Power

- 220 - 240 V~ 50/60 Hz
- 10 A maximum total input current.
- Lightning strike protection meets ANSI/IEEE standard 62.31-1980. Can withstand voltage surges of up to 6000 V and current surges of up to 3000 A.
- Contact Lutron for applications where the electrical distribution system does not have a connection to earth, an IT network per IEC 60364, such as an ungrounded Delta feed.

Regulatory Approvals

- Lutron Quality Systems registered to ISO 9001.2015
- RoHS Compliant
- IEC/EN 60669-2-5
- CE marked
- Rated for 150 W of LEDi per IEC 60669

Environment

- See **Mounting** on page 7 for thermal specifications.
- Relative humidity: less than 90% non-condensing.
- For indoor use only.

Output Zone Ratings

- Each zone has no minimum load requirement.
- When programmed to "auto detect" mode, the module starts in reverse-phase (trailing-edge) and if an incompatible load is detected, it will convert to forward-phase (leading-edge).
- Internal relay provides an air gap off when all zones are off.
- One load type per zone.
- Output must not be used to control general purpose receptacles.





- Output must be directly connected to the load.
- Output breakers or switches must not be used.
- Run a separate neutral for each load circuit. A common neutral connection is not recommended.
- Module may be powered by Ground Fault Interrupter (GFI) or Residual Current Circuit Breaker with Overload (RCBO) protected circuit, if required. Load circuit wiring (from breaker to module to load) must be run in its own non-metallic conduit, or nuisance tripping may occur. Maximum wire length between the module and the load must be less than 30.5 m (100 ft).
- For applications requiring 0–10 V_{DC} control, use a QSNE-4T10-D.
- For applications requiring higher wattage ratings, use a power booster (PHPM-PA-277/DV).
- For dimmable loads only. For applications requiring switching control, use the QSNE-4S10-D.

Job Name: <input type="text"/> Job Number: <input type="text"/>	Model Numbers: <input type="text"/> <input type="text"/>
---	---

Specifications *(continued)*

Output Zone Ratings *(continued)*

Each zone is rated for the following wattage and load types (module 10 A maximum)^{A, B}:

Load Type	Zone 1 Rating	Zone 2, 3 and 4 Rating (per zone)
LED ^B 	1.7 A (400 W)	1.0 A (250 W)
Incandescent/Halogen, ELV  	1 200 W	800 W
Neon/Cold Cathode, MLV ^D  	800 VA (525 W ^C)	500 VA (375 W ^C)

^A Additional load type options are available in the programming software suite, some may require an interface. Contact Lutron for details.

^B Ratings listed refer to the LED driver input current/wattage. Refer to Lutron.com/ledtool for compatibility testing results. Using LED fixtures that are not tested can result in the fixtures not turning-on or poor dimming quality. LED dimming performance can vary from fixture to fixture and cannot be guaranteed.

^C Actual lamp wattage.

^D Only use iron core transformers intended for use with an electronic switch or dimmer per Clause 8.3 of IEC/EN 60669-2-1.

Job Name: <input type="text"/>	Model Numbers: <input type="text"/>	
Job Number: <input type="text"/>	<input type="text"/>	<input type="text"/>

Specifications *(continued)*

Terminals (Torque, wire gauge & type ratings)

- Mains wiring: 0.6 N•m (5 in-lbs)
2.5 mm² to 4.0 mm² (14 AWG to 10 AWG)
(single wire, solid or stranded)
- Zone wiring: 0.6 N•m (5 in-lbs)
2.5 mm² to 4.0 mm² (14 AWG to 10 AWG)
(single wire, solid or stranded)
- CCI wiring: 0.6 N•m (5 in-lbs)
0.5 mm² to 4.0 mm² (20 AWG to 10 AWG)
(single wire, solid or stranded)
0.5 mm² to 1.5 mm² (20 AWG to 16 AWG)
(two wires, solid or stranded)
- QS Link: 0.6 N•m (5 in-lbs)
Power (terminal 1):
0.25 mm² to 2.5 mm² (22 AWG to 12 AWG)
(single wire, solid or stranded)
0.25 mm² to 1.0 mm² (22 AWG to 18 AWG)
(two wires, solid or stranded)
Data (terminals 3 and 4):
1 pair, twisted and screened,
0.25 mm² to 2.5 mm² (22 AWG to 12 AWG)
(single wire, solid or stranded)
0.25 mm² to 1.0 mm² (22 AWG to 18 AWG)
(two wires, solid or stranded)

Out of Box Functionality

This section describes the default functionality when the module is first installed.

Emergency Contact Closure Input (CCI)

- When the CCI is open, the module will enter emergency mode, which will turn on all loads to their emergency level and disable control of local zones and QS devices.
- When the CCI is closed or jumpered, zones will return to the settings or levels they were at prior to entering emergency mode.
Note: Module will process any sensor events received while in emergency mode after it exits emergency mode.

Normal Mode Operation

- By default each zone is set to an Auto Detect load type with ON and OFF control only. Each zone will turn load ON or OFF until it is configured via module programming.
- Zone and raise/lower buttons on the module can be used to:
 - Turn loads ON and OFF.
 - Dim loads up and down after manually setting a load type.

Programming Options

QS Standalone Programming

- Requires ESN programming interface (QSE-CI-AP-D).
- Requires compatible iOS programming device using the Energi Savr application. Refer to the Energi Savr Node Handheld Programming Guide (P/N 040384) at www.lutron.com
- Does not support local button programming.

Athena System Programming

- Program using Athena Designer software suite.

Quantum System Programming

- Program using the Quantum Designer software suite.

Job Name: <input style="width: 90%; height: 20px;" type="text"/>	Model Numbers: <input style="width: 60%; height: 20px;" type="text"/> <input style="width: 35%; height: 20px;" type="text"/>	
Job Number: <input style="width: 100px; height: 20px;" type="text"/>	<input style="width: 100%; height: 20px;" type="text"/>	<input style="width: 100%; height: 20px;" type="text"/>

Mounting

- Module is 12 DIN modules wide, 216 mm (8.5 in).
- Mount in a Lutron DIN panel (see Lutron Specification Submittal 3691194 at www.lutron.com) or in an IP20 (minimum) enclosure with an integrated DIN rail (please refer to Lutron P/N 048466 at www.lutron.com).
- Mount module in orientation shown with arrow in the up direction.
- Mount to DIN rail by pressing module onto rail with clips locked. To remove from rail, unlock clips using a screwdriver.
- Mount in an accessible and serviceable location.
- Module generates heat, maximum 75 BTUs/Hour.
- Mount module such that all the conditions below are met:
 - Room ambient temperature is between 0 °C and 40 °C (32 °F and 104 °F)
 - Temperature inside mounting panel, within 20 mm (0.8 in) of module, is between 0 °C and 60 °C (32 °F and 140 °F)
 - Calibration point maximum: 70 °C (158 °F)

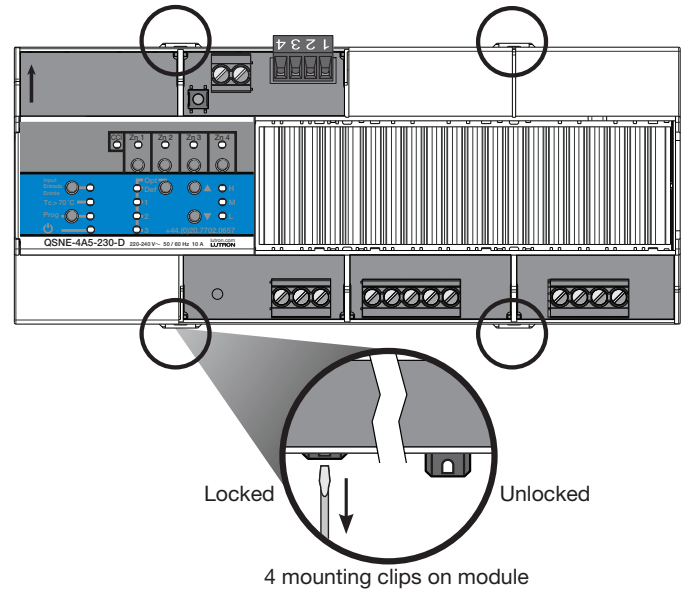

Mechanical Dimensions

Left Side View

Front View

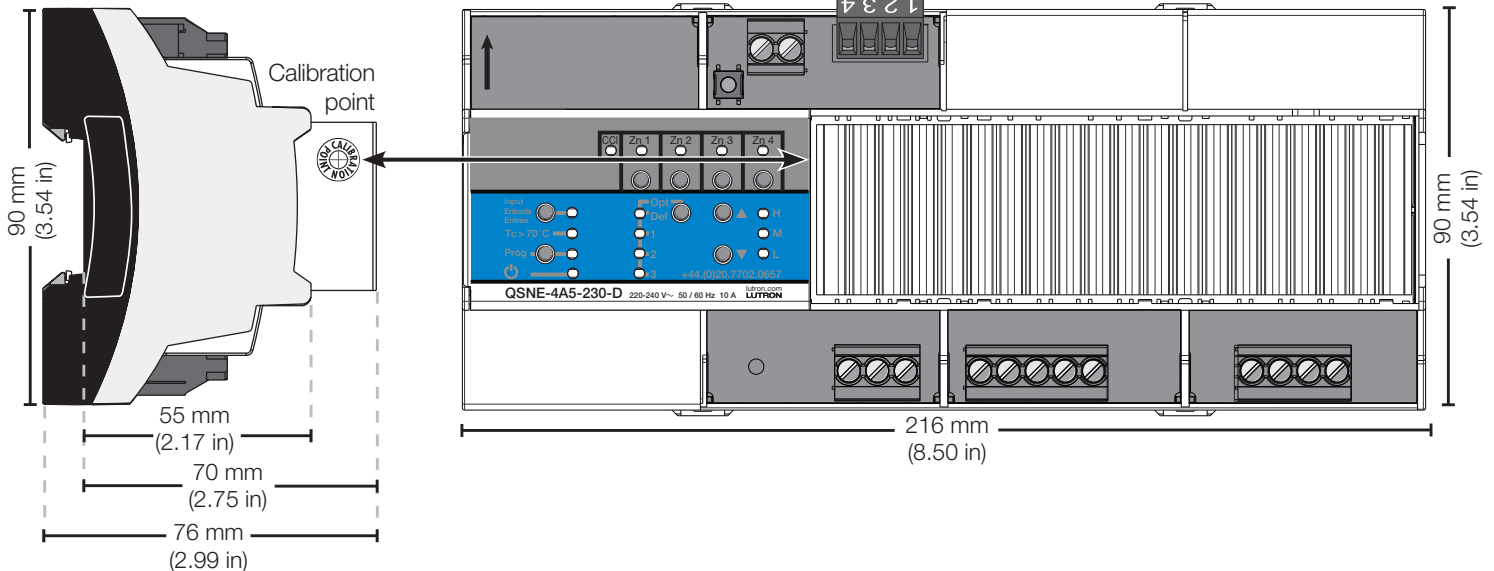

Job Name:	Model Numbers:	
<input type="text"/>	<input type="text"/>	<input type="text"/>
Job Number:	<input type="text"/>	<input type="text"/>

Overview of Wiring Terminals

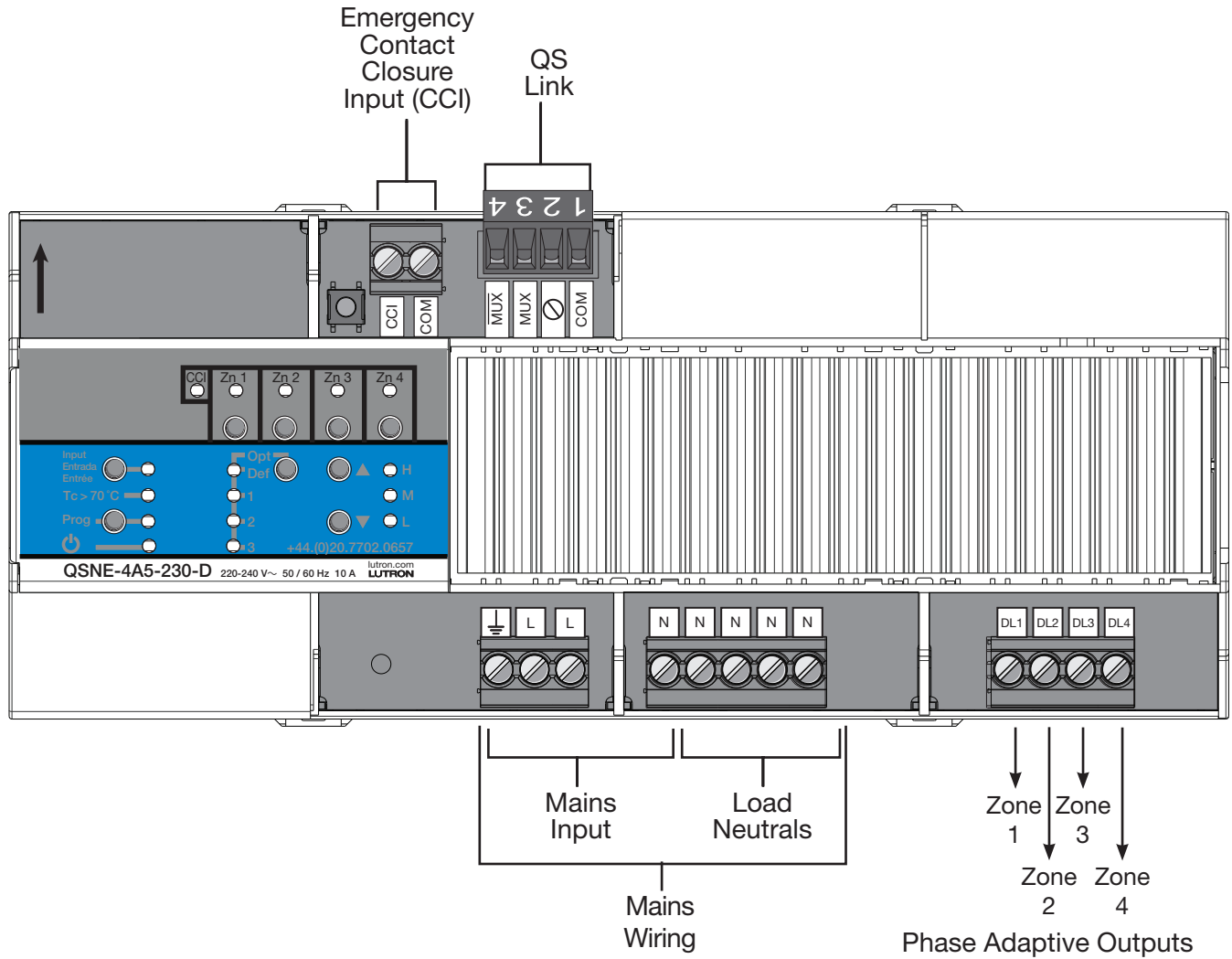

Job Name:	Model Numbers:	
<input type="text"/>	<input type="text"/>	<input type="text"/>
Job Number:	<input type="text"/>	<input type="text"/>

Verify Wiring

- Apply power directly to loads to first identify any load or wiring faults prior to connecting loads to module.

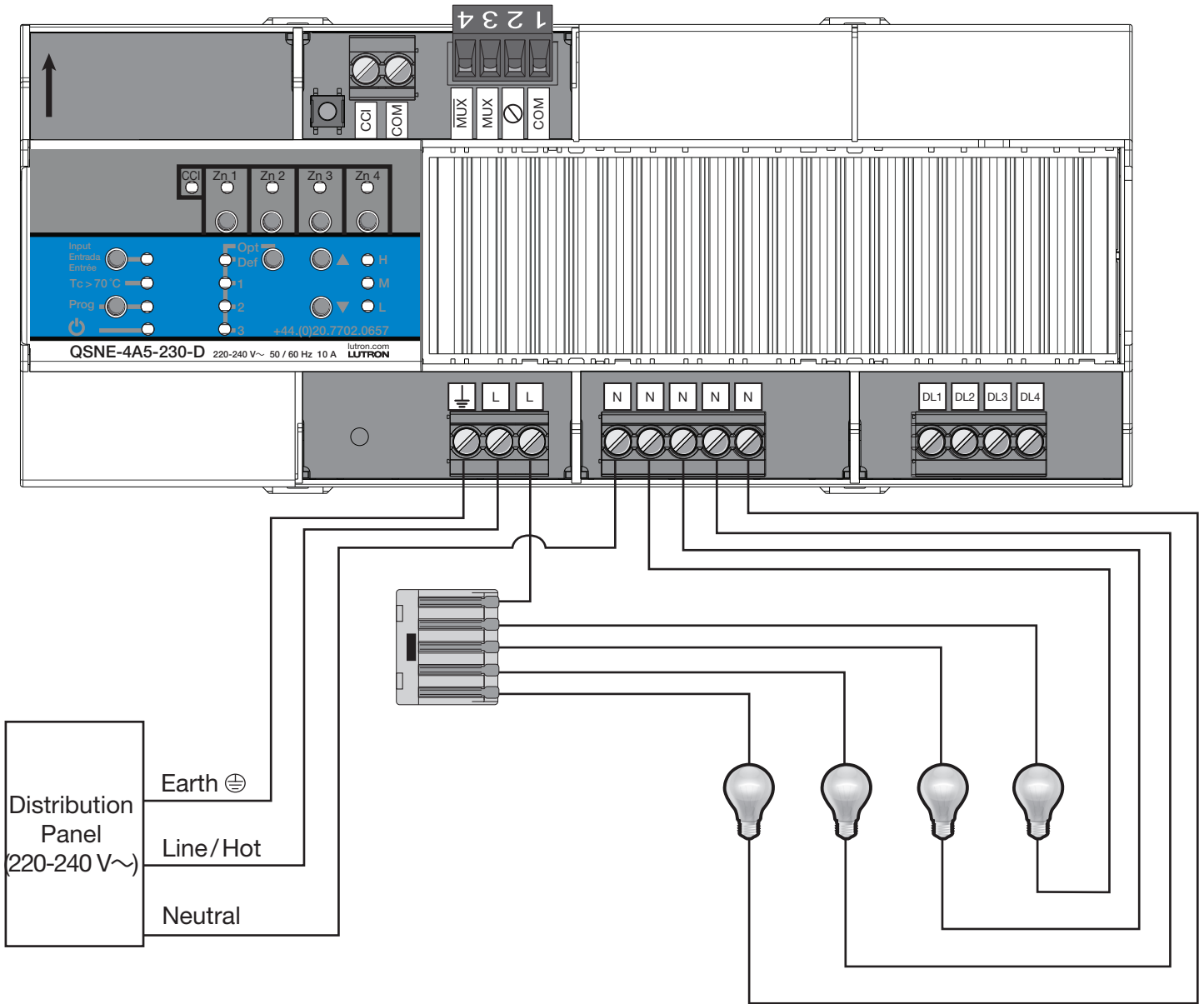

Job Name:	Model Numbers:	
<input type="text"/>	<input type="text"/>	<input type="text"/>
Job Number:	<input type="text"/>	<input type="text"/>

Mains Voltage Wiring

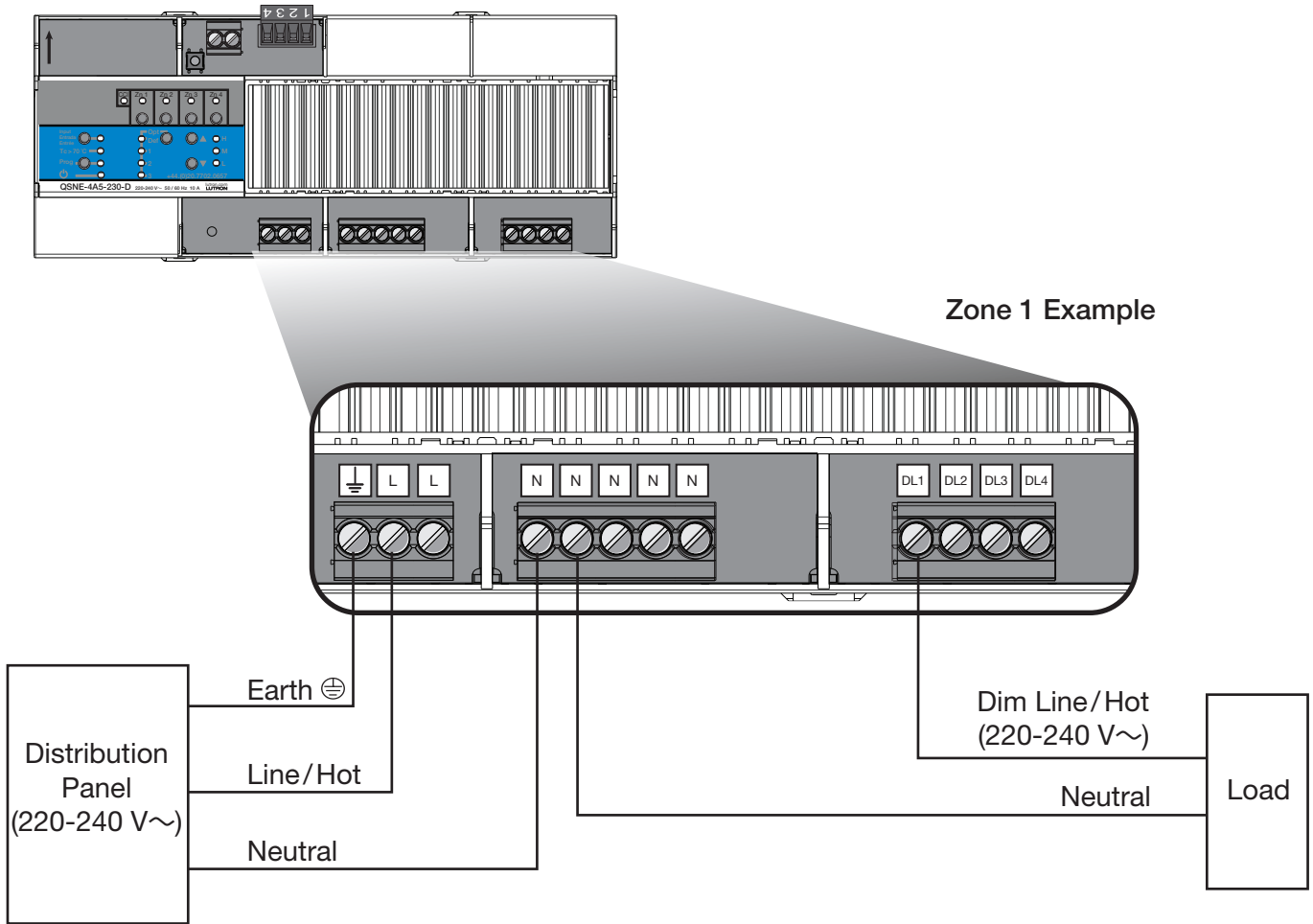

Wiring from Distribution to Phase-Adaptive Power Module

- Run line/hot, neutral, and earth (⊕) wires from a 220-240 V~ 50/60 Hz feed to the power module.
- Run a separate neutral for each load circuit for best performance.

Mains Wiring and IEC® PELV Separation

- Follow appropriate local and national codes to ensure proper separation.

Job Name:	Model Numbers:	
<input type="text"/>	<input type="text"/>	<input type="text"/>
Job Number:	<input type="text"/>	<input type="text"/>

Wiring: Emergency Contact Closure Input

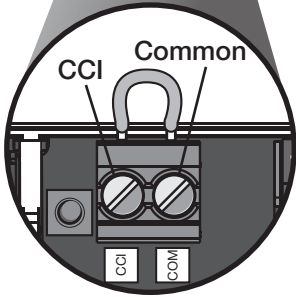
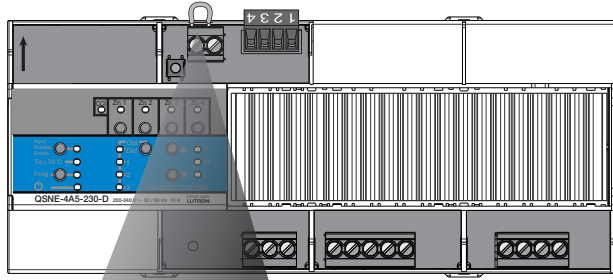

Note: Shown with pre-installed jumper.

IEC® PELV/NEC Class 2 Emergency Contact Closure Input

- Emergency Contact Closure Input (CCI) wiring is IEC® PELV/NEC Class 2. Follow all applicable national and local codes for proper circuit separation and protection.
- The CCI is a local control only and cannot control other modules over the QS link. A maximum of 32 modules may be connected in parallel to a CCO device if the event is intended to affect multiple devices.
- When in emergency mode, all zone outputs will be at their programmed emergency light level (configurable for each zone, default is 100%). All sensors and controls are locked out.
- Contact closure input is normally closed (NC). The module is shipped with a jumper pre-installed.

Note: The module will default to emergency mode if the CCI is left open. If no Emergency Contact Closure Input is required, leave the wire jumper in the CCI terminals.

Job Name:	Model Numbers:	
<input type="text"/>	<input type="text"/>	<input type="text"/>
Job Number:	<input type="text"/>	<input type="text"/>

Wiring: QS Link

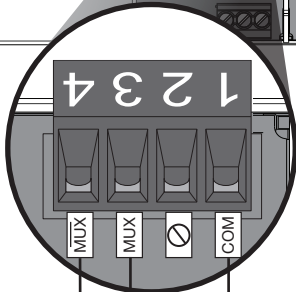
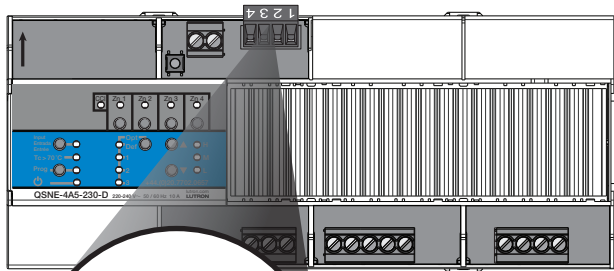

- (1) COM
- (2) Do Not Connect Terminal 2¹
- (3) MUX
- (4) MUX

QS Link IEC® PELV/NEC Class 2 Wiring

- Follow all applicable national and local codes for proper circuit separation and protection.
- Link communicates using IEC® PELV/NEC Class 2 wiring.
- Wiring may be daisy chained or T-tapped.
- Do NOT connect terminal 2.

QS Link Wiring Options

QS Link Wiring Length	Wire Gauge	Available from Lutron in one cable:*
Less than 153 m (502 ft)	Power (terminals 1 and 2): 1 pair 1.0 mm ² (18 AWG)	QS-CBL-LSZH (Low-Smoke Zero-Halogen) GRX-CBL-346S (non plenum) GRX-PCBL-346S (plenum)
	Data (terminals 3 and 4): 1 pair 0.5 mm ² (22 AWG), twisted and screened	
153 m to 610 m (502 ft to 2000 ft)	Power (terminals 1 and 2): 1 pair 4.0 mm ² (12 AWG)	GRX-CBL-46L (non plenum) GRX-PCBL-46L (plenum)
	Data (terminals 3 and 4): 1 pair 0.5 mm ² (22 AWG), twisted and screened	

Daisy-Chain Wiring Example

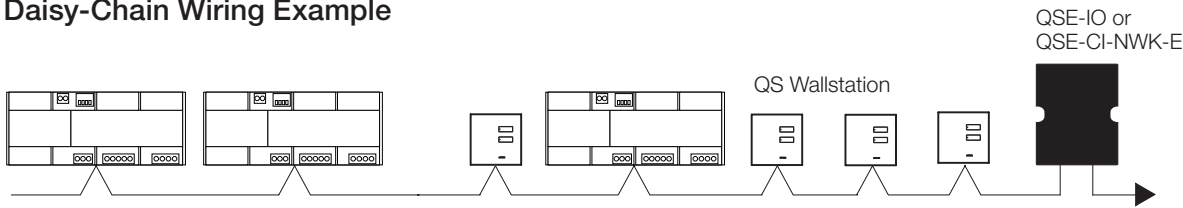

T-Tap Wiring Example

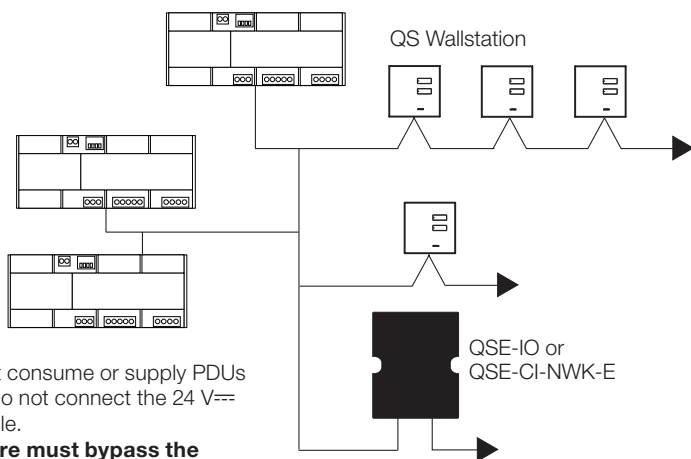

¹ Module does not consume or supply PDUs on the QS link. Do not connect the 24 V_{DC} wire to the module.

Note: 24 V_{DC} wire must bypass the module if other devices on the link consume PDUs.

Lutron, Lutron, LED+, Energi Savr Node, Athena, Radio Powr Savr, Pico and Quantum are trademarks or registered trademarks of Lutron Electronics Co., Inc. in the US and/or other countries.

Apple, iPhone, and iPod touch are trademarks of Apple Inc., registered in the U.S. and other countries.

All other product names, logos, and brands are property of their respective owners.

Job Name:	Model Numbers:	
<input type="text"/>	<input type="text"/>	<input type="text"/>
Job Number:	<input type="text"/>	<input type="text"/>