

Energi Savr Node QS Phase Adaptive Fixture Controller

The Energi Savr Node QS family is a group of modular products for the control of lighting loads. This product is compatible with Quantum and QS systems.

Features

- Automatically selects leading-edge or trailing-edge dimming for incandescent/halogen, electronic/magnetic low-voltage and neon/cold cathode light sources.
- Controls dimmable CFL/LED loads. Refer to Lutron P/N 048478 on www.lutron.com for compatibility with dimmable CFL/LED light sources.
- RTISS Equipped technology compensates for incoming line-voltage variations (up to $\pm 2\%$ change in frequency/second) such as changes in Root Mean Square (RMS) voltage, frequency shifts, harmonics and line noise.
- RTISS-TE operates on the trailing edge of the AC sine wave. This allows for true instantaneous voltage compensation.

System Example

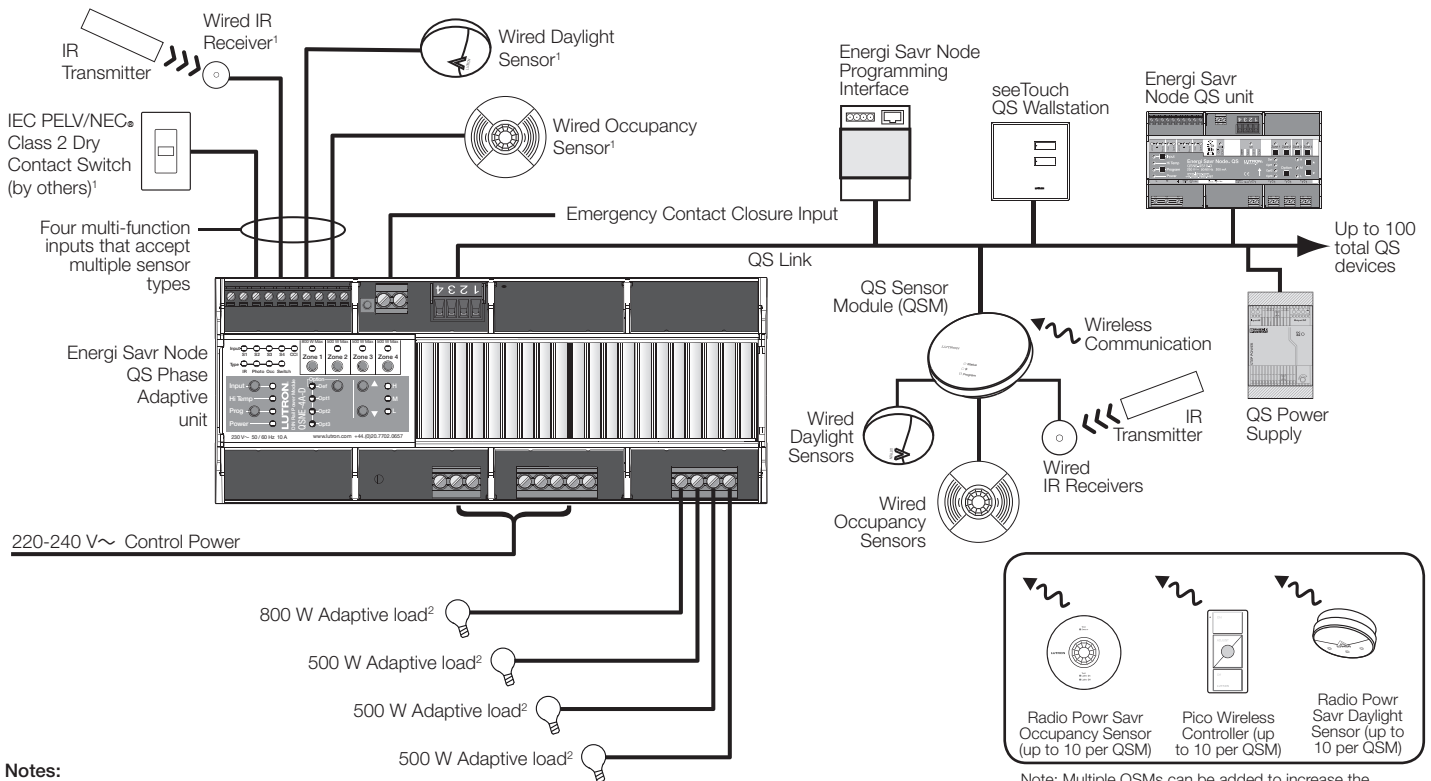

Notes:
¹ Up to four wired inputs total (of any type).
² See "Output Zone Ratings" in "Specifications" section, for specific load type ratings.

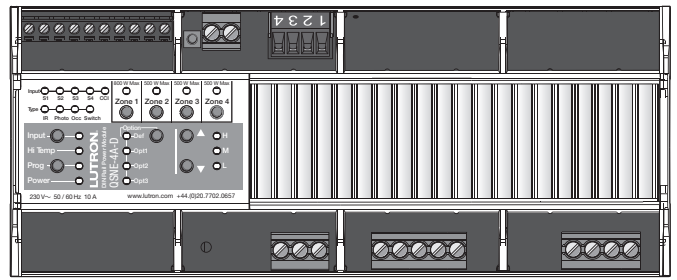

QSNE-4A-D

- Unit is 12 DIN modules (216 mm) wide.
- Four multi-function inputs compatible with the following:
 - Daylight sensors
 - Occupancy sensors
 - IR receivers
 - IEC PELV/NEC® Class 2 dry contact switches
- Provides air gap off (when all zones are off).
- Integral protection for common temporary over-current and over-voltage conditions.
- LEDs on front of unit provide diagnostic information.
- Includes QS link for seamless integration of lights and controls.

Job Name:	Model Numbers:	
<input type="text"/>	<input type="text"/>	<input type="text"/>
Job Number:	<input type="text"/>	<input type="text"/>

Specifications

Power

- 220–240 V~ 50/60 Hz
- 10 A maximum total input current
- Lightning strike protection meets ANSI/IEEE standard 62.31-1980. Can withstand voltage surges of up to 6 000 V and current surges of up to 3 000 A.
- 24 V== 132 mA, 4 PDUs supplied

Regulatory Approvals

- IEC/EN 60669-2-1
- CE marked
- Lutron Quality Systems registered to ISO 9001.2008

Environment

- See **Mounting** section for thermal specifications
- Relative humidity: less than 90% non-condensing
- For indoor use only

Output Zone Ratings

- **No Derating** is required if all the conditions below are met:
 - Calibration point maximum is 70 °C
 - Room ambient temperature is between 0 °C and 30 °C
 - Panel ambient temperature is between 0 °C and 50 °C
- **100 W Derating** is required on all zones for a single module in a single non-ventilated DIN enclosure if:
 - The room ambient temperature is between 30 °C and 40 °C.
- **200 W Derating** is required on all zones for multiple row non-ventilated DIN enclosure if:
 - The room ambient temperature is between 30 °C and 40 °C.

Output Zone Ratings (continued)

- Each zone has no minimum load requirement.
- Automatically selects leading-edge or trailing-edge dimming or can also be manually configured for a specific load type.
- Internal relay provides an air gap off when all zones are off.
- One load type per zone.
- Output must not be used to control receptacles.
- Output must be directly connected to the load. Contact Lutron for applications with load side breakers.
- Run a separate neutral for each load circuit. A common neutral connection is not recommended.
- Maximum wire length between the Energi Savr Node unit and the load must be less than 30.5 m.
- Unit may be powered by Ground Fault Interrupter (GFI) or Residual Current Circuit Breaker with Overload (RCBO) protected circuit if required. Load circuit wiring (from breaker to unit to load) must be run in its own non-metallic conduit, or nuisance tripping may occur.
- For applications requiring 0–10 V== control, use Ten Volt Interface (GRX-TVI) or the QSNE-4T10-D.
- For applications requiring higher wattage ratings, use a power booster (NGRX-PB, NGRX-ELVI, NGRX-FDBI).

Each zone is rated for the following wattage and load types ^{A, B}:

Load Type	Zone 1 Rating			Zone 2, 3 and 4 Rating (per zone)		
	No Derating	100 W Derating	200 W Derating	No Derating	100 W Derating	200 W Derating
Incandescent/Halogen	800 W	700 W	600 W	500 W	400 W	300 W
Electronic Low-Voltage	800 W	700 W	600 W	500 W	400 W	300 W
Magnetic Low-Voltage ^D	800 VA (600 W ^C)	700 VA (525 W ^C)	600 VA (450 W ^C)	500 VA (375 W ^C)	400 VA (300 W ^C)	300 VA (225 W ^C)
Neon/Cold Cathode ^D	800 VA (600 W ^C)	700 VA (525 W ^C)	600 VA (450 W ^C)	500 VA (375 W ^C)	400 VA (300 W ^C)	300 VA (225 W ^C)

^A Additional load type options are available in the Quantum software suite, some may require an interface. Contact Lutron for details.

^B Refer to Lutron P/N 048478 on www.lutron.com for compatibility with dimmable CFL/LED light sources.

^C Actual lamp wattage.

^D Only use iron core transformers intended for use with an electronic switch or dimmer per Clause 8.3 of IEC/EN 60669-2-1.

Job Name: <input style="width: 90%;" type="text"/>	Model Numbers: <input style="width: 95%;" type="text"/>
Job Number: <input style="width: 80%;" type="text"/>	<input style="width: 95%;" type="text"/>

Specifications (continued)

Terminals (Torque, wire gauge & type ratings)

- Mains wiring: 0.6 N•m
1.0 mm² to 4.0 mm²
(single wire, solid or stranded)
1.0 mm² to 1.5 mm²
(two wires, solid or stranded)
- Zone wiring: 0.6 N•m
1.0 mm² to 4.0 mm²
(single wire, solid or stranded)
- CCI wiring: 0.6 N•m
0.5 mm² to 4.0 mm²
(single wire, solid or stranded)
- Multi-function
Input Wiring: 0.6 N•m
0.5 mm² to 1.5 mm²
(single wire, solid or stranded)
- QS Link: 0.6 N•m
0.5 mm² to 4.0 mm²
(single wire, solid or stranded)
0.5 mm² to 1.0 mm²
(two wires, solid or stranded)

Multi-Function Inputs

- Each multi-function input is compatible with occupancy and daylight sensors as well as IR receivers and IEC PELV/NEC® Class 2 dry contact switches.
- Dedicated Power Supply Output for each input
 - 20 V_{DC} 50 mA maximum each.
 - An auxiliary supply is required if an input requires more than 50 mA.

Wired Occupancy Sensors

- Each of the inputs can power one Lutron occupancy sensor, up to four sensors per unit.
- Lutron occupancy sensors can be configured to have one of the following modes:
 - Occupancy: Automatic On, Automatic Off
 - Vacancy: Manual On, Automatic Off
- Each area's occupied and unoccupied scene can be configured independently.

- Each occupancy sensor can control one or more zones.
- Occupancy sensor must provide a dry contact closure or solid-state output.
- Each unit may be controlled by occupancy sensors connected to other devices, up to a maximum of sixteen occupancy sensors.

Wired Infrared (IR) Receivers

- Each of the inputs can power one IR receiver, up to four receivers per unit.
- Use Lutron IR receivers and compatible transmitters for personal control of individual lighting zones.

Wired Daylight Sensors

- Each of the inputs can power one daylight sensor, up to four sensors per unit.
- Lutron daylight sensors allow daylight harvesting and can be programmed to affect light output.
- Use Lutron EC-DIR-WH sensors to control one or more zones.
- Each zone may be controlled by a maximum of two daylight sensors.

Dry Contact Switches

- Must be rated for IEC PELV/NEC® Class 2 operation.
- Can be configured for momentary or maintained operation.
- Zones can be programmed to any level including Off.

Job Name: <input style="width: 90%;" type="text"/>	Model Numbers: <input style="width: 95%;" type="text"/>	
Job Number: <input style="width: 80%;" type="text"/>	<input style="width: 95%;" type="text"/>	<input style="width: 95%;" type="text"/>

Specifications (continued)

Communication with GRAFIK Eye QS

- Energi Savr Node QS unit zones can be configured to respond to GRAFIK Eye QS scene buttons when associated with the GRAFIK Eye QS.
- Energi Savr Node QS unit zones can be configured to respond to scene commands initiated by the GRAFIK Eye QS astronomic time clock when associated with the GRAFIK Eye QS.
- Energi Savr Node QS unit operates in afterhours mode when associated with a GRAFIK Eye QS that is in afterhours mode.
- Zones on the GRAFIK Eye QS may be configured to remotely control zones on the Energi Savr Node QS unit.

Communication with QSE-IO

- Energi Savr Node QS unit zones can be configured to respond to scene commands initiated by the QSE-IO in scene selection mode.
- Energi Savr Node QS unit can be configured to respond to zone toggle or occupancy sensor commands initiated by the QSE-IO in scene toggle mode or occupancy sensor mode.
- Refer to the QSE-IO Specification Submittal for more information.

Communication with QSE-CI-NWK-E

- Integrate Energi Savr Node QS units with touchscreens, PCs, A/V systems or other digital systems and devices.
- Refer to Lutron Integration Protocol guide on www.lutron.com for more information.

QSM (QS Sensor Module): Integrating Wired and Wireless Sensors

- Use the QSM to integrate Radio Powr Savr Occupancy/Vacancy sensors, Radio Powr Savr Daylight sensors, and Pico Wireless Controllers to control zones on the Energi Savr Node QS unit.
- Wire up to 4 wired inputs (of any type listed below) total to the QSM
 - Daylight sensors
 - Occupancy sensors
 - Infrared (IR) receivers
- The Radio Powr Savr sensors and Pico Wireless Controllers associated with the QSM should be mounted within 18 m line of sight, or 9 m through walls, of the QSM.
- Refer to QSM Specification Submittal for more information.

seeTouch QS Wallstation

- seeTouch QS wallstations can be configured to:
 - select scenes 1-16 and off
 - toggle zones between preset and off
 - set and display partition status
 - enable/disable panic mode
 - start/stop sequencing
- In scene mode, wallstations can be assigned to one or more Energi Savr Node QS units connected to the QS link.
- In zone toggle mode, zone buttons can be assigned to one or more zones on any Energi Savr Node QS unit connected to the QS link.
- LED indicator displays scene or zone status.

Job Name: <input style="width: 90%; height: 20px;" type="text"/>	Model Numbers: <input style="width: 60%; height: 20px;" type="text"/> <input style="width: 35%; height: 20px;" type="text"/>	
Job Number: <input style="width: 80%; height: 20px;" type="text"/>	<input style="width: 100%; height: 20px;" type="text"/>	<input style="width: 100%; height: 20px;" type="text"/>

Out-of-Box (Default) Functionality

Multi-Function Inputs (Occupancy, Photo, IR Sensors, or Dry Contact Switches)

- Sensors or switches will have no effect on any of the zones until set up via unit programming.

seeTouch QS Wallstations

- All seeTouch QS lighting wallstations are Scene keypads by default.
- Scenes 1-16 will dim lights to the preset levels in the table below:

Scene #	Light Level: All Zones
1, 5-16	100%
2	75%
3	50%
4	25%

- Scene Off will turn all the lights Off.

Emergency Contact Closure Input (CCI)

- When the CCI is open, the Energi Savr Node QS unit will enter Emergency Mode, which will turn on all loads to their emergency level and disable control of local zones and QS devices.
- When the CCI is closed or jumpered, Energi Savr Node QS unit zones will return to the settings or levels they were at prior to entering emergency mode.

Note: Unit will process any sensor events received while in emergency mode after it exits emergency mode.

Normal Mode Operation

- By default each zone is set to an Unassigned/Non-Dim load type. Each zone will switch load on or off until it is configured via unit programming. Once configured, the load type cannot be changed back to Unassigned/Non-Dim.
- Zone and raise/lower buttons on the unit can be used to:
 - turn loads on and off.
 - dim loads up and down.
- Input and sensor status LEDs ('Occupancy', 'Photo', 'IR', and 'Switch') verify connections to dry contact switches and sensors.

Job Name: <input style="width: 90%; height: 20px;" type="text"/>	Model Numbers: <input style="width: 60%; height: 20px;" type="text"/> <input style="width: 35%; height: 20px;" type="text"/>	
Job Number: <input style="width: 80%; height: 20px;" type="text"/>	<input style="width: 30%; height: 20px;" type="text"/>	<input style="width: 30%; height: 20px;" type="text"/>

Programming Options

Details for each option can be found in the “Programming Options and Features” table on the next page.

Manual Programming:

- Use buttons on the front of the Energi Savr Node unit.
- Use manual programming in installations with only one Energi Savr Node unit and with one QS Sensor Module (QSM) or fewer on the QS link.
- See the manual programming guide (032416) for details.

HHD Programming

- Requires ESN Programming Interface (QSE-CI-AP-D).
- Requires *Apple iPod touch* or *iPhone* mobile digital device.
- Use the intuitive programming application for the *Apple iPod touch* or *iPhone* to program systems with multiple Energi Savr Node units and QSMs on the QS link.

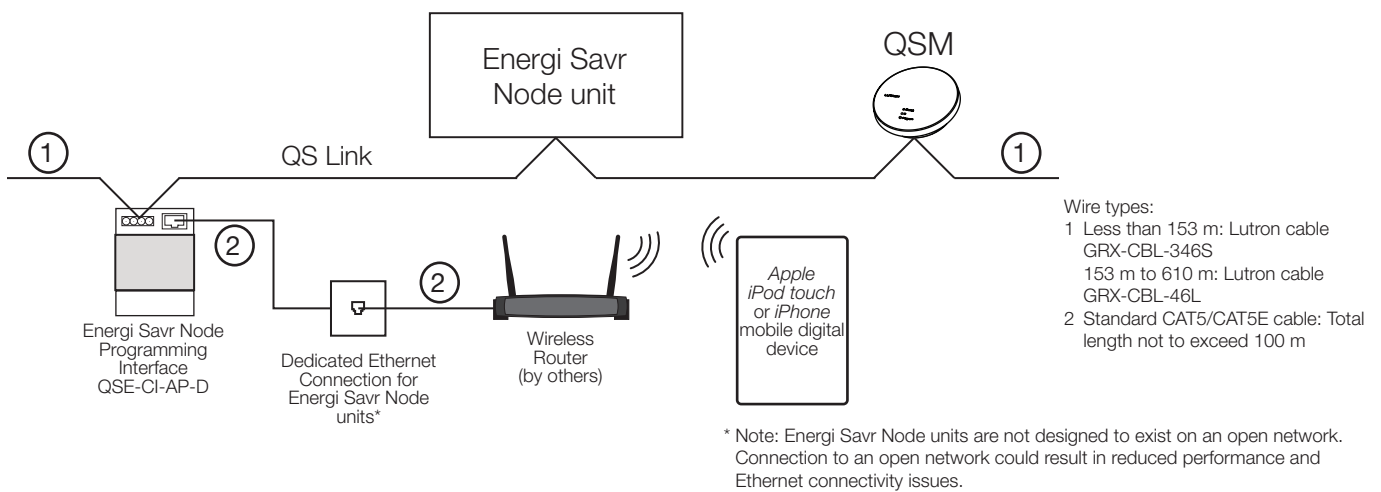

- Wireless router only required for programming with an *Apple iPod touch* or *iPhone*.
- Wireless router may be removed for normal operation.
- Ethernet connection may be made via an an Energi Savr Node Programming Interface (QSE-CI-AP-D) or an Energi Savr Node unit with integral Ethernet jack.
- Lutron recommends that an Energi Savr Node Programming Interface (or Energi Savr Node unit with Ethernet jack) be wired to an Ethernet jack in the space for ease of access and proximity to power for the wireless router.
- Works with any standard wireless router that supports multicast packets.
- *Apple iPod touch* or *iPhone* can program all Energi Savr Node units connected to an Energi Savr Node Programming Interface via the QS Link (except when part of a Quantum system).
- Energi Savr app is required and is available from the *Apple AppStore* online marketplace.

Quantum Programming

- Programming is achieved using the Quantum software suite.
- Requires a Quantum Processor.

Apple, iPhone, and iPod touch are trademarks of Apple Inc., registered in the U.S. and other countries. AppStore is a service mark of Apple Inc.

Job Name: <input type="text"/>	Model Numbers: <input type="text"/>	
Job Number: <input type="text"/>	<input type="text"/>	<input type="text"/>

Programming Options and Features

	Manual Programming	HHD Programming: <ul style="list-style-type: none"> • Requires ESN Programming Interface QSE-CI-AP-D • Requires <i>Apple iPod touch</i> or <i>iPhone</i> mobile digital device
Energi Savr Node units (ESNs) Connected to QS Link	Not more than 1	Multiple: 100 QS devices and 100 zone limits apply
QS Sensor Modules (QSMs) Connected to QS link	Not more than 1	Multiple: 100 QS devices limit applies

Wired Occupancy Sensors

System Limits	2 connected directly to ESN unit Up to 4 wired to QSM	Up to 100 total occupancy sensors per QS link (wired + wireless)
Can be assigned to...	Any zone(s) on the ESN unit	Zones on ESN unit or share to other ESN units on same QS link
Occupancy Dependency and Grouping Supported	No	Yes

Wireless Occupancy Sensors

System Limits	Associate 10 occupancy sensors to QSM to control zones on the ESN unit	Up to 100 total occupancy sensors per QS link (wired + wireless)
Can be assigned to...	Any zone(s) on the ESN unit	Zones on ESN unit or share to other ESN units on same QS link
Occupancy Dependency and Grouping Supported	No	Yes

Continued on next page...

Apple, iPhone, and iPod touch are trademarks of Apple Inc., registered in the U.S. and other countries.

Job Name: <input style="width: 90%; height: 20px;" type="text"/>	Model Numbers: <input style="width: 60%; height: 20px;" type="text"/> <input style="width: 35%; height: 20px;" type="text"/>	
Job Number: <input style="width: 80%; height: 20px;" type="text"/>	<input style="width: 30%; height: 20px;" type="text"/>	<input style="width: 30%; height: 20px;" type="text"/>

Programming Options and Features (continued)

Manual Programming	HHD Programming: <ul style="list-style-type: none"> • Requires ESN Programming Interface QSE-CI-AP-D • Requires <i>Apple iPod touch</i> or <i>iPhone</i> mobile digital device
---------------------------	--

Wired Daylight Sensors

System Limits	Maximum of 1 daylight sensor per zone 2 connect directly to the ESN unit Additional daylight sensors can connect to the QSM	Maximum of 2 daylight sensors per zone Up to 100 total daylight sensors per QS link (wired + wireless)
Can be assigned to...	Any zone(s) on the ESN unit	Zones on ESN unit or share to other ESN units on same QS link
Disable daylighting in Scenes	No	Yes

Wireless Daylight Sensors

System Limits	Maximum of 1 daylight sensor per zone Associate wireless daylight sensors to the QSM	Maximum of 2 daylight sensors per zone Associate up to 10 wireless daylight sensors per QSM Up to 100 total daylight sensors per QS link (wired + wireless)
Can be assigned to...	Any zone(s) on the ESN unit	Zones on ESN unit or share to other ESN units on same QS link
Disable daylighting in Scenes	No	Yes

Pico Wireless Controllers

Can be assigned to...	Any zone on the local ESN unit	Any number of zones or areas on ESN units on same QS link
-----------------------	--------------------------------	---

IR Receivers and Wallstations

System Limits	2 connect directly to the ESN unit Up to 4 wired to the QSM	Up to 100 total controls per QS link (wired wallstations, IR receivers)
Can be assigned to...	Any zone on the local ESN unit	Zones on ESN unit or share to other ESN units on same QS link

Emergency Contact Closure Input

Can be assigned to...	Any zone(s) on the ESN unit	Any or all local ESN unit zones
Emergency Light level	Configurable	Configurable

Continued on next page...

Apple, iPhone, and iPod touch are trademarks of Apple Inc., registered in the U.S. and other countries.

Job Name: <input style="width: 90%;" type="text"/>	Model Numbers: <input style="width: 60%;" type="text"/> <input style="width: 40%;" type="text"/>	
Job Number: <input style="width: 150px;" type="text"/>	<input style="width: 300px;" type="text"/>	<input style="width: 300px;" type="text"/>

Programming Options and Features (continued)

Manual Programming	HHD Programming: <ul style="list-style-type: none"> • Requires ESN Programming Interface QSE-CI-AP-D • Requires <i>Apple iPod touch</i> or <i>iPhone</i> mobile digital device
---------------------------	--

seeTouch QS wallstations

Scene Keypads assigned to...	Any zone(s) on the ESN unit	Any zone(s) on one or more ESN units on the QS link
Scene + off keypads assigned to...	Any zone(s) on the ESN unit	Any zone(s) on one or more ESN units on the QS link
Zone toggle keypad buttons assigned to...	Any zone(s) on the ESN unit	Any zone(s) on one or more ESN units on the QS link
Change Keypad to Scene or Zone	Yes	Yes
Changing keypads to shade, panic, fine tune	No	Yes

Zone Configuration Parameters

Load type	Auto, ELV, MLV	Auto, ELV, MLV
High-end trim	Adjustable	Adjustable
Low-end trim	Adjustable	Adjustable
Absolute minimum level	Adjustable	Adjustable

Scenes

Available scenes	Scenes 1-16 and off	Scenes 1-16 and off
------------------	---------------------	---------------------

GRAFIK Eye® QS	Follow GRAFIK Eye QS scenes, timeclock events, and/or afterhours events	Follow GRAFIK Eye QS scenes, timeclock events, and/or afterhours events
-----------------------	---	---

QSE-IO	Scene, zone toggle, occupancy	Scene, zone toggle, occupancy
---------------	-------------------------------	-------------------------------

QSE-CI-NWK-E	Yes	Yes
---------------------	-----	-----

Apple, iPhone, and iPod touch are trademarks of Apple Inc., registered in the U.S. and other countries.

Job Name:	Model Numbers:	
<input style="width: 90%;" type="text"/>	<input style="width: 30%;" type="text"/>	<input style="width: 30%;" type="text"/>
Job Number:	<input style="width: 30%;" type="text"/>	<input style="width: 30%;" type="text"/>

Mounting

- See Lutron P/N 048466 at www.lutron.com for more information on mounting and installation in panels with integrated DIN rail.
- Mount in IP20 (minimum) rated consumer panel or breaker panel with integrated DIN rail.
- Unit is 12 DIN modules (216 mm) wide.
- Mount unit in orientation shown.
- Unit may be mounted by unlocking the four mounting clips on the back of the unit. Clips must be locked once unit is securely attached to the DIN rail.
- Mount in an accessible and serviceable location.
- Unit generates heat, maximum 75 BTUs/Hour
- Mount unit such that all the conditions below are met:
 - Room ambient temperature is between 0 °C and 30 °C
 - Temperature inside mounting panel, within 20 mm of unit, is between 0 °C and 50 °C
 - Calibration point maximum: 70 °C

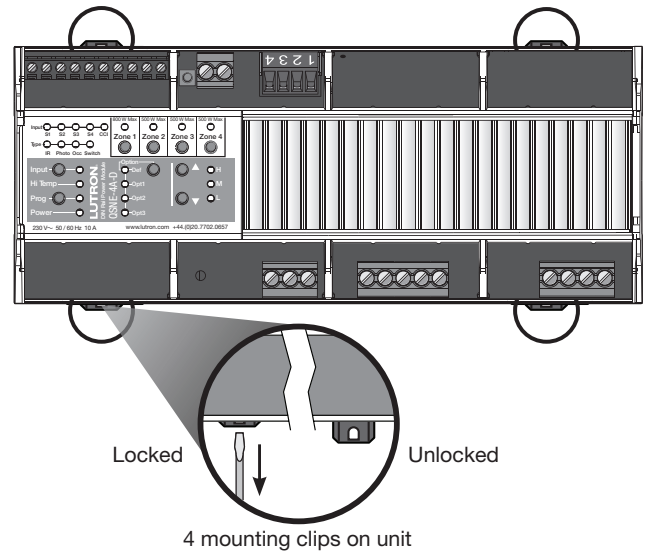

Mechanical Dimensions

Left Side View

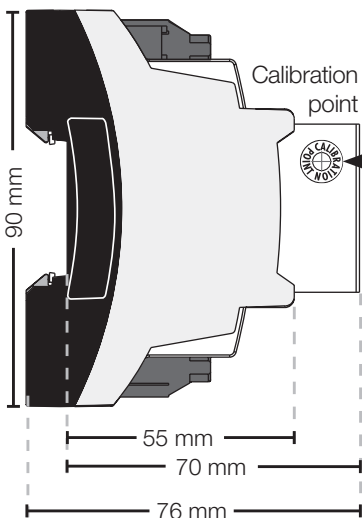

Front View

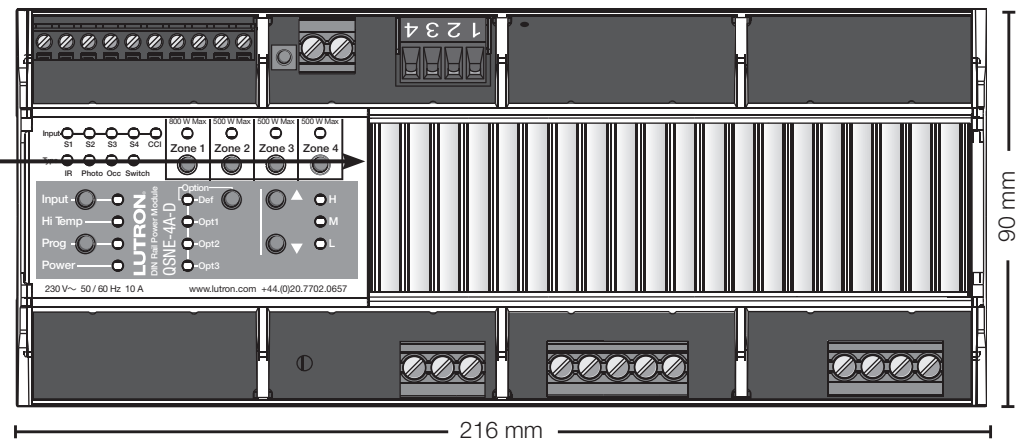

Job Name:	Model Numbers:	
<input type="text"/>	<input type="text"/>	<input type="text"/>
Job Number:	<input type="text"/>	<input type="text"/>

Overview of Wiring Terminals

QSNE-4A-D

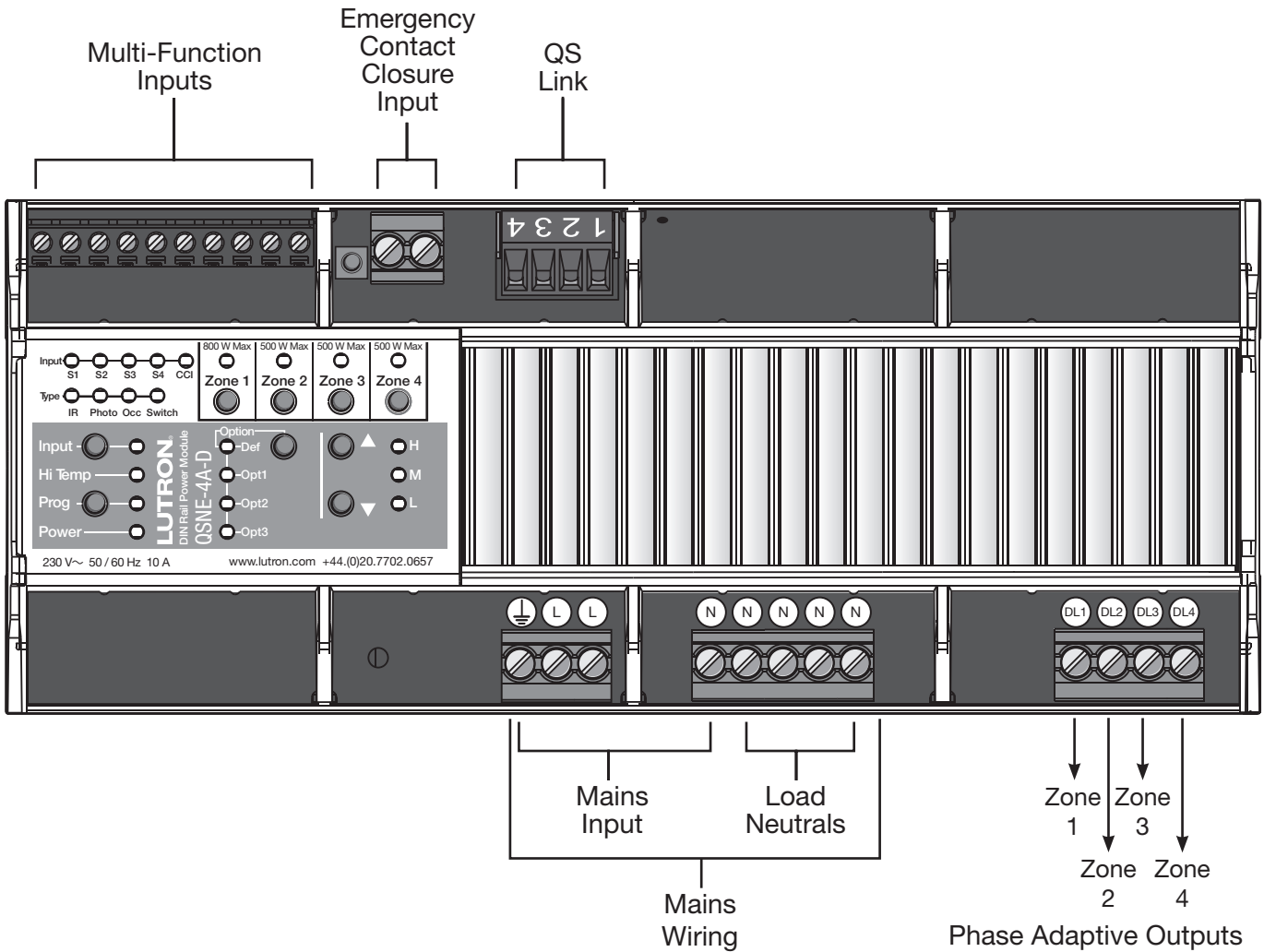

Job Name:	Model Numbers:	
<input type="text"/>	<input type="text"/>	<input type="text"/>
Job Number:	<input type="text"/>	<input type="text"/>

Wiring Verification

QSNE-4A-D

- Unit ships with bypass connector pre-installed for load wiring verification. Bypass connector is used to apply power to loads to identify any load or wiring faults prior to wiring loads to unit.
- Load wiring must be verified before wiring loads to unit.
- To verify wiring:
 1. Turn off power.
 2. Wire loads to provided connector.
 3. Apply power, ensure the desired loads are powered and properly wired.
 4. Turn off power and wire loads to DL terminals on unit.

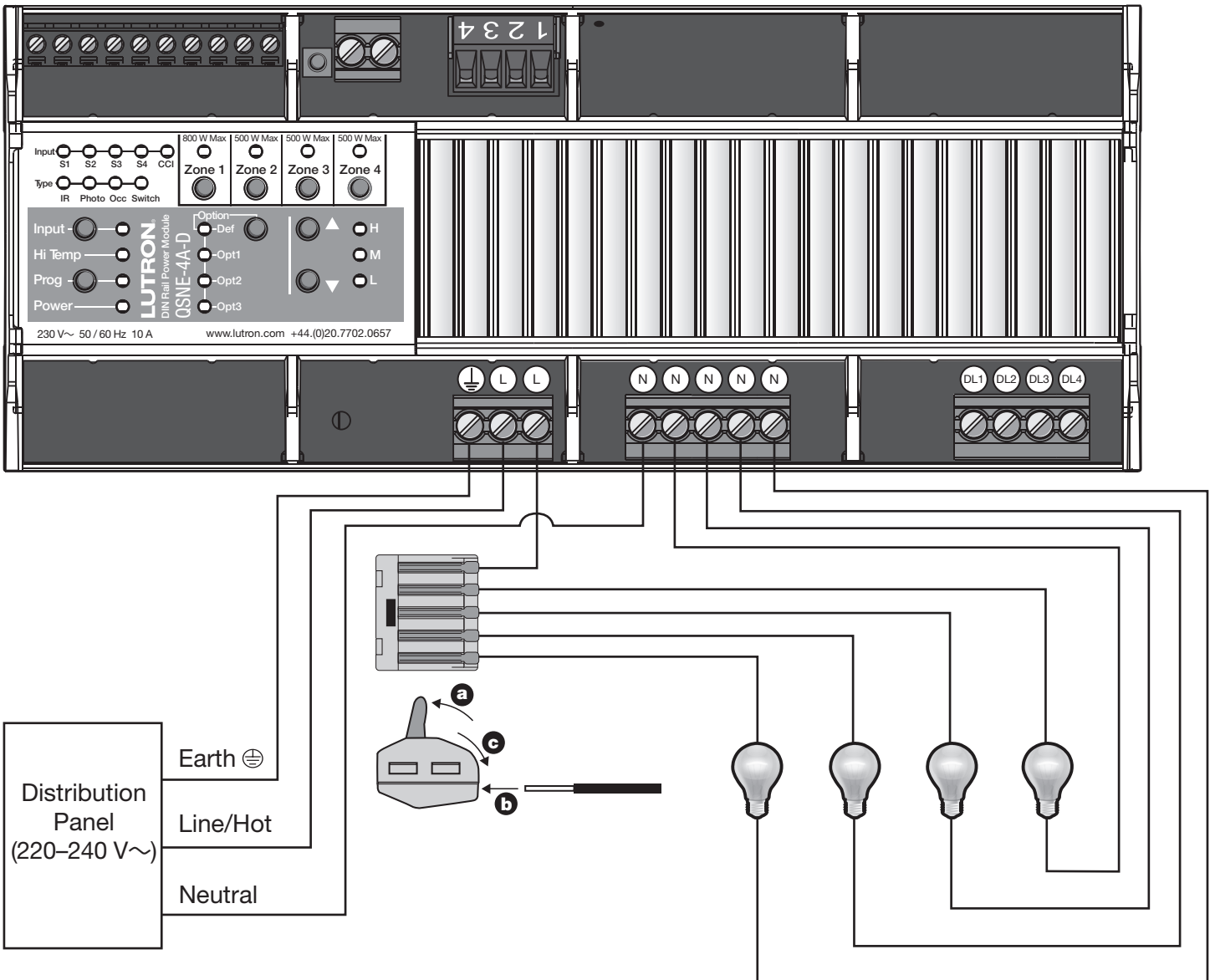

Job Name:	Model Numbers:	
<input type="text"/>	<input type="text"/>	<input type="text"/>
Job Number:	<input type="text"/>	<input type="text"/>

Mains Voltage Wiring

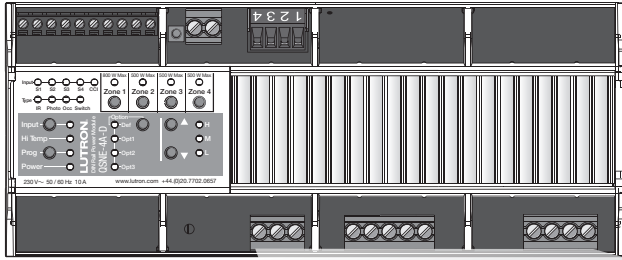

Zone 1 Example

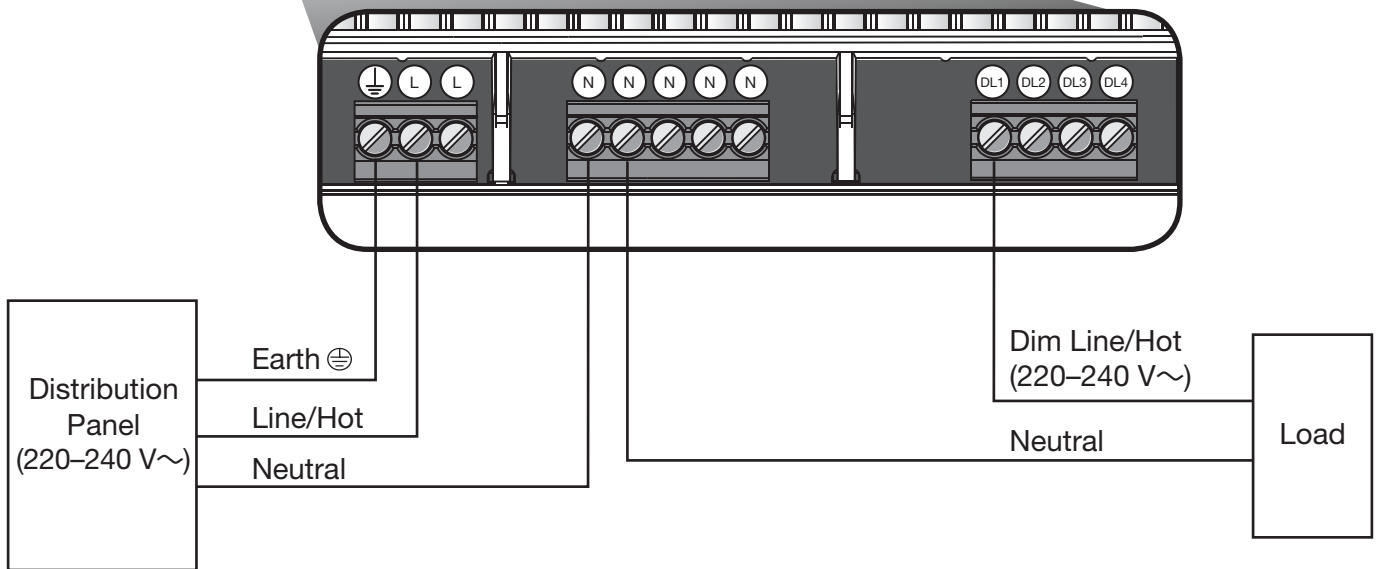

Wiring from Distribution to Energi Savr Node™ QS unit

- Turn off all circuit breakers or isolators feeding the Energi Savr Node QS unit at distribution panel.
- Run line/hot, neutral, and earth \oplus wires from a 220–240 V~ 50/60 Hz feed to the Energi Savr Node QS unit.
- Run a separate neutral for each load circuit. A common neutral connection is not recommended.

Mains Wiring and IEC PELV Separation

- Follow appropriate local and national codes to avoid violating required separation guidelines.

Job Name:	Model Numbers:	
<input type="text"/>	<input type="text"/>	<input type="text"/>
Job Number:	<input type="text"/>	<input type="text"/>

Wiring: Emergency Contact Closure Input

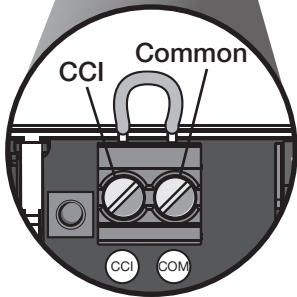
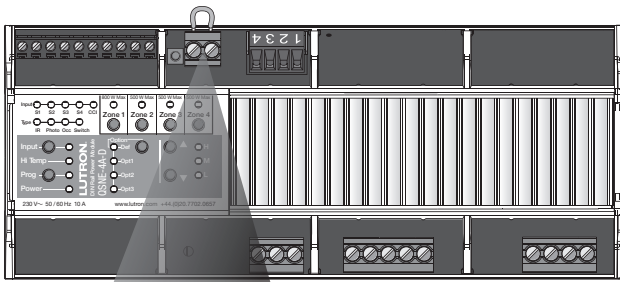

Note: Shown with pre-installed jumper.

IEC PELV Emergency Contact Closure Input

- Contact Closure Input (CCI) wiring is IEC PELV/NEC Class 2. Follow all applicable national and local codes for proper circuit separation and protection.
- Turn off all breakers or isolators feeding the Energi Savr Node QS unit at distribution panel before servicing unit.
- The CCI is a local control only and cannot control other Energi Savr Node QS units over the QS link. A maximum of 32 Energi Savr Node QS units may be connected in parallel to an Emergency or Manual override device if the event is intended to affect multiple devices.
- When in emergency mode, all zone outputs will be at their programmed emergency light level (configurable for each zone, default is 100%). All sensors and controls are locked out.
- Emergency contact closure input is normally closed (NC). The Energi Savr Node QS unit is shipped with a jumper pre-installed.

Note: The Energi Savr Node QS unit will default to Emergency Mode if the CCI is left open. If no Emergency Contact Closure Input is required, please leave the wire jumper in the CCI terminals.

Job Name:	Model Numbers:	
<input type="text"/>	<input type="text"/>	<input type="text"/>
Job Number:	<input type="text"/>	<input type="text"/>

Wiring: QS Link

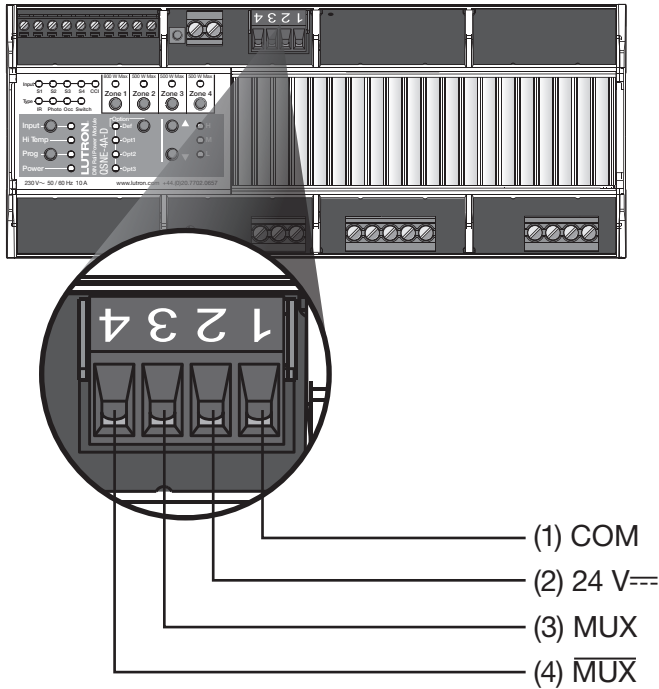

QS Link IEC PELV Wiring

- Link communicates using IEC PELV/NEC® Class 2 wiring.
- Turn off all breakers or isolators feeding the Energi Savr Node QS unit at distribution panel before servicing unit.
- Follow all applicable national and local codes for proper circuit separation and protection.
- Wiring may be daisy chained or t-tapped.
- Total length of QS link must not exceed 600 m.
- For lengths under 150 m, use 1.0 mm² or larger conductors for control power (24 V_{DC}, COM).
- For lengths over 150 m, use 4.0 mm² conductors for control power (24 V_{DC}, COM).
- Use one, twisted-shielded pair of 1.0 mm² conductors for data link (MUX, $\overline{\text{MUX}}$).
- Terminal 2 (+24 V_{DC}) should NEVER be connected between devices that supply PDUs.
- See “Power Draw Units on the QS Link” (Lutron P/N 369405) on www.lutron.com for QS link limits and PDU counts.

Daisy-Chain Wiring Example

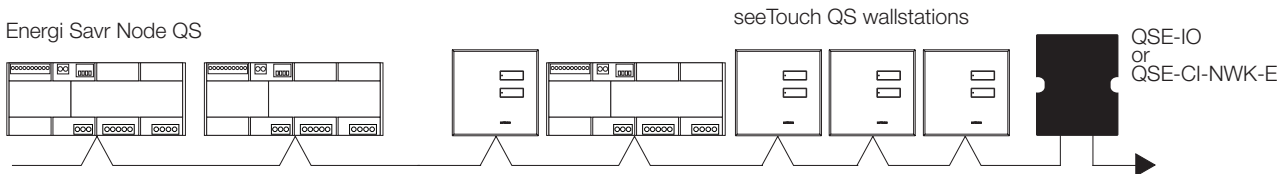

T-Tap Wiring Example

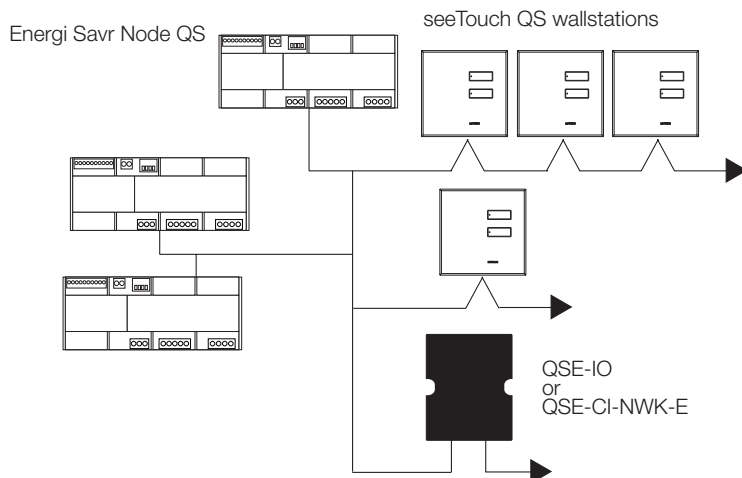

Job Name:	Model Numbers:	
<input type="text"/>	<input type="text"/>	<input type="text"/>
Job Number:	<input type="text"/>	<input type="text"/>

Wiring: IEC PELV Multi-Function Inputs

Wiring Instructions:

- All input wiring is IEC PELV/NEC® Class 2. Follow all applicable national and local codes for proper circuit separation and protection.
- Input terminals accept 0.5 mm² to 1.5 mm² solid or stranded conductors.
- Mains voltage and IEC PELV/NEC® Class 2 wiring must be kept separate.
- **Note:** One device per input.
- Turn off all breakers or isolators feeding the Energi Savr Node QS unit at distribution panel before servicing unit.

Daylight Sensor:

- Connect the four conductors to the four terminals as shown.
 Red = 20 V== White = IR*
 Black = Common Yellow = Daylight
- Maximum wire length between the Daylight Sensor and the Energi Savr Node QS unit must be less than 46 m.
- One daylight sensor can be wired to each input.

Example Sensor Setup

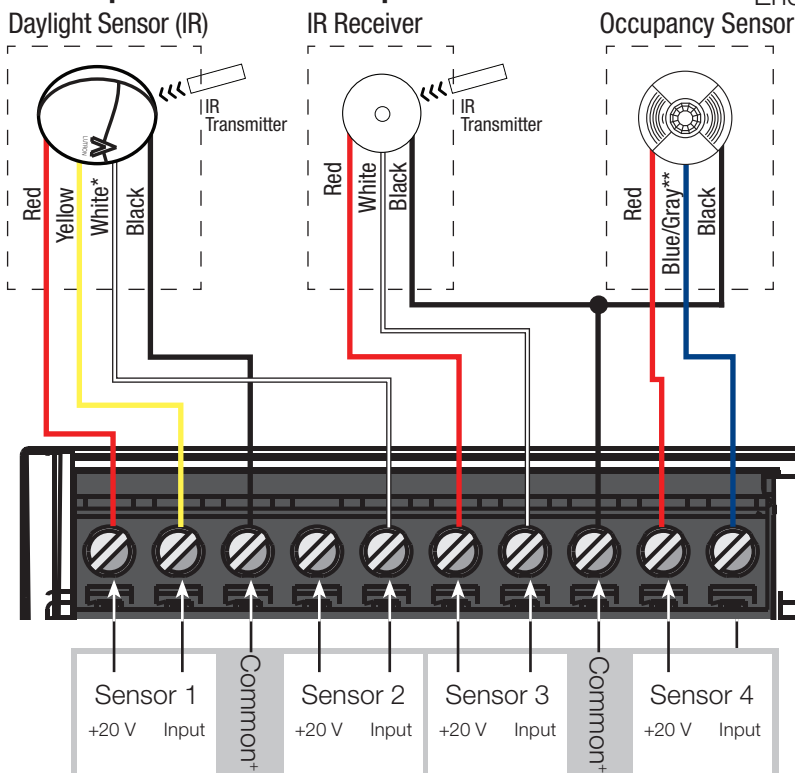

- Consult the daylight sensor specification sheet to properly install sensor.
- Do not place the sensor above pendants, fixtures, directly below lighting fixtures, or within skylight wells.

Occupancy Sensor:

- Connect three conductors to three terminals as shown.
- One occupancy sensor can be wired to each input.
- Maximum wire length between the sensor and the Energi Savr Node QS unit must be less than 46 m.
Note: If sensor has an automatic sensitivity or threshold adjustment, Lutron recommends disabling it.

IR Receiver:

- Connect the three conductors to the three terminals as shown.
- Maximum wire length between the receiver and the Energi Savr Node QS unit must be less than 46 m.
- One IR receiver can be wired to each input.

Dry Contact Switch:

- Connect one conductor to common and the other to input (not shown).
- Maximum wire length between the switch and the Energi Savr Node QS unit must be less than 46 m.

- * **Note:** Daylight sensor with IR may require two inputs. Only one IR device may be connected per input. If the IR signal from a daylight sensor is connected, another control may not be connected to the same input. If IR is not being used, leave white wire disconnected.
- ** **Note:** Connect the gray wire on -R Occupancy Sensor models.
- + **Note:** Sensor Commons are internally shorted.

Lutron, Lutron, Quantum, RTISS Equipped, SeeTouch, Pico, and GRAFIK Eye are registered trademarks of Lutron Electronics Co., Inc. registered in the U.S. and other countries.

Energi Savr Node, RTISS-TE, and Radio Powr Savr are trademarks of Lutron Electronics Co., Inc.

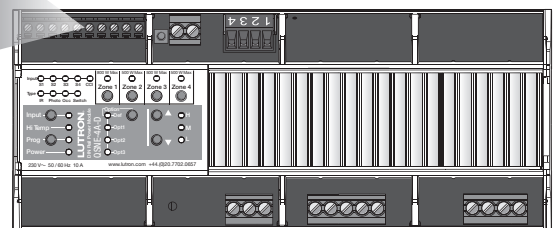

Job Name:	Model Numbers:		
<input type="text"/>	<input type="text"/>	<input type="text"/>	<input type="text"/>
Job Number:	<input type="text"/>	<input type="text"/>	<input type="text"/>