

# Ineo Wallstation

## Installation guide

### Introduction

#### Welcome

The Ineo wallstation from Cooper Controls provides sleek appearance combined with complete control and flexibility. The adaptable design allows you to choose from a range of button combinations, which can be fitted and changed at any time. Where fitted, raise and lower buttons compliment the usual selection buttons to allow immediate changes to the intensity of any scene.

An optional infrared remote control allows similar functionality from anywhere within the room via the detector built into the front panel of the Ineo wallstation. All control signals are transmitted to the source controller(s) using iCANnet connections.

### Supplied parts

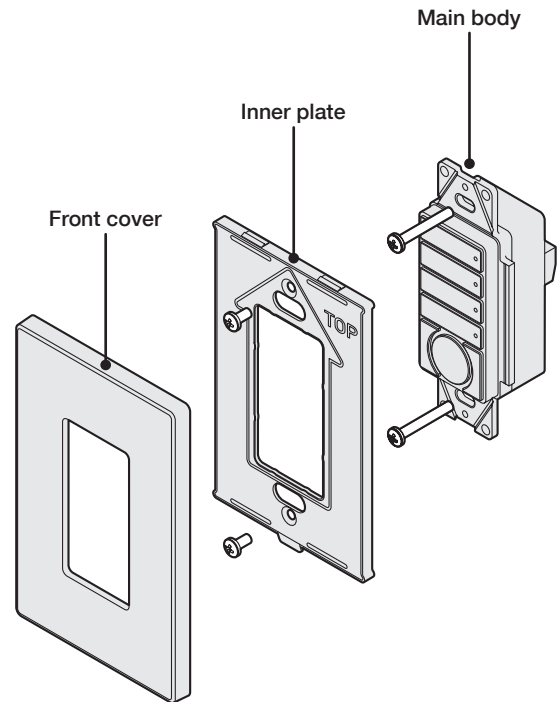

### Dimensions

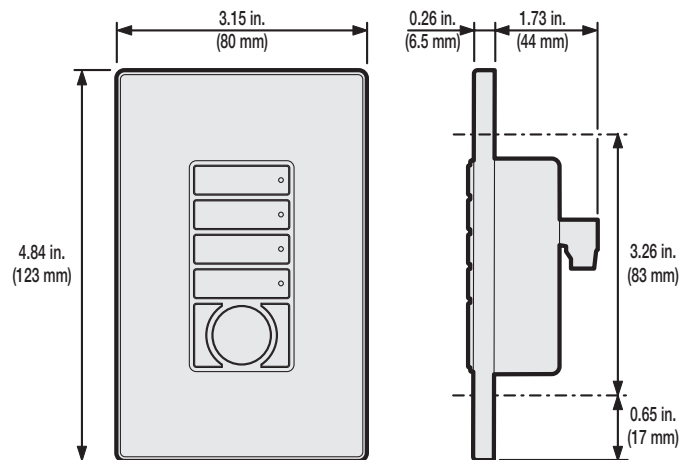

The Ineo wallstation is intended to fit into a single gang US style wall box with a minimum internal depth of 2 in. (51 mm). Wall boxes available from Cooper Controls.

## Disassembling the wallstation

1. On the underside of the front cover, beneath the lower buttons, locate the small central recess. Carefully insert a small implement (such as a pen or screwdriver) into the recess and lever the front cover gently away from the inner plate.

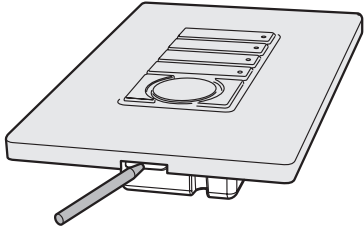

2. Unclip the front cover from the top of the inner plate.

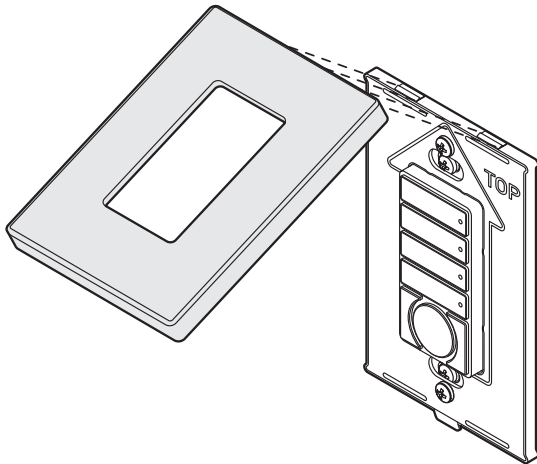

3. Remove the two retaining screws located above and below the buttons and lift the inner plate away from the main body.

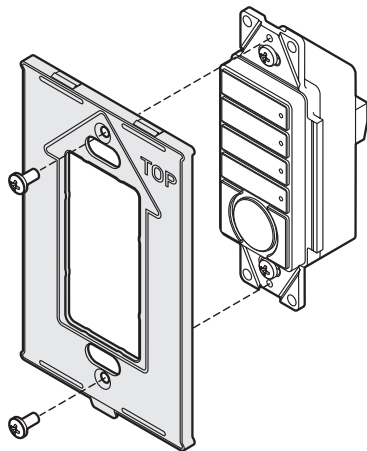

4. Store all removed parts safe from damage.

## Fixing to a wallbox

The Ineo wallstation is intended to fit into a single gang US style wall box with a minimum internal depth of 2 in. (51 mm).

With the Ineo wallstation disassembled (see opposite), use the two supplied long screws to secure the rear chassis plate to the wall box.

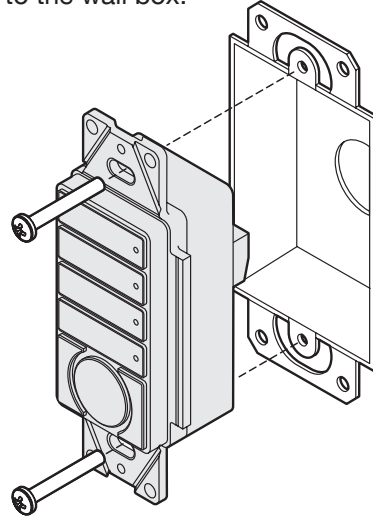

## Control wiring

The Ineo wallstation uses iCANnet connections to ensure reliable and responsive transfer of control signals between multiple devices.

Cable connections are made to a removable 5-way connector block located at the rear of the Ineo wallstation main body:

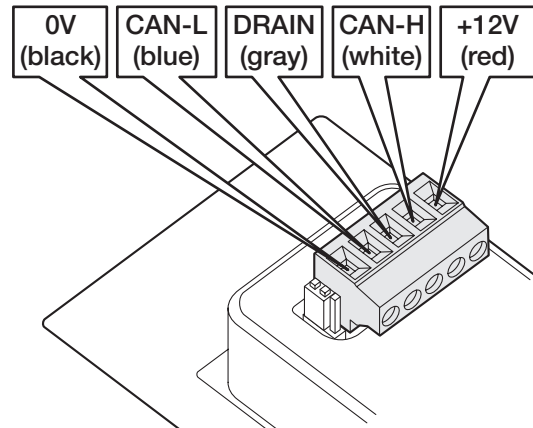

Cable type:

Cooper LCCNP (Non Plenum)  
or Cooper LCCP (Plenum)  
or Belden1502R (Non Plenum)  
or 1502P (Plenum)

Maximum cable length:

1000m/3200ft

Devices per segment:

100 without a bridge

## Termination

The iCANnet link is a 'daisy chain' protocol that requires termination on the devices located at either end of the chain.

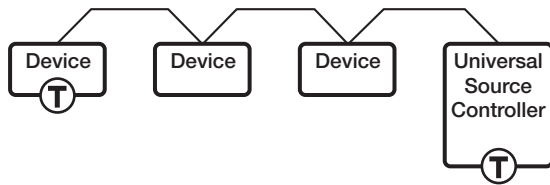

The Ineo wallstation is supplied with termination enabled as standard. If the Ineo wallstation is not connected as an end device in the chain, you need to disable termination.

To disable termination, move the jumper from the upper two pins to the lower two pins, as shown here:

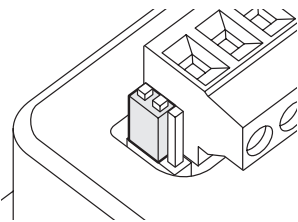

Termination on

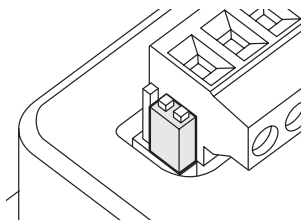

Termination off

## Changing buttons

The Ineo wallstation allows you to change the buttons in order to customize its appearance.

1. Remove the front cover and inner plate as discussed in 'Disassembling the wallstation'.
2. Locate the four clips (two on each side) of the button frame. Carefully press in all four clips to disengage the button frame and pull the frame away from the main body.
3. You can now remove the buttons from the frame and replace them (and the frame), as necessary.
4. With the new buttons in place within the frame, align its clips with the four holes of the main body and press it into place so that all four clips click as they lock.

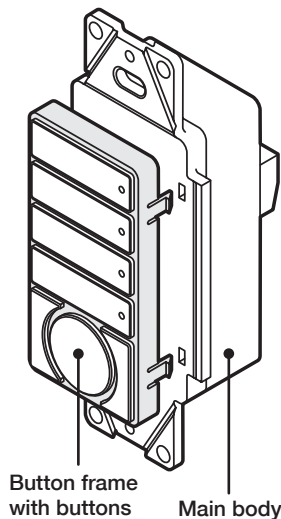

## Reassembling the wallstation

1. Place the inner plate onto the main body (noting the orientation arrow). With the plate in place, insert and lightly tighten the two retaining screws.

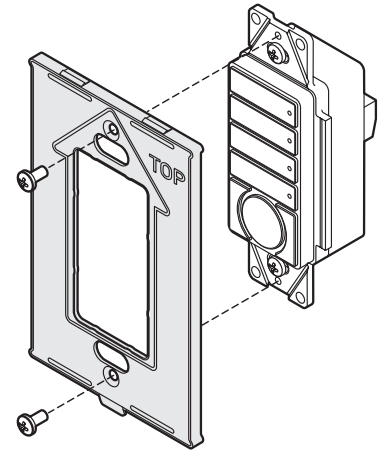

2. Attach the top edge of the front cover to the main body.

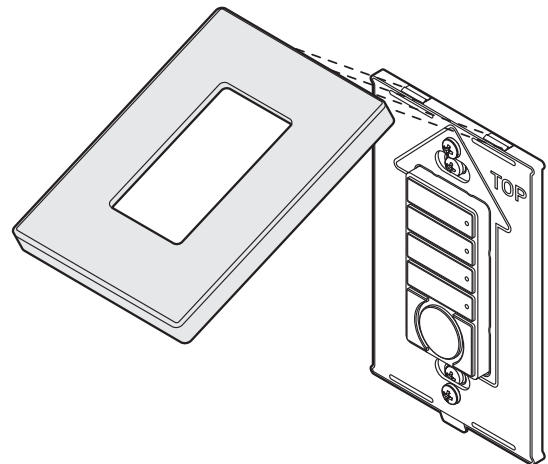

3. Angle the front cover down and press the lower part of it against the inner plate until it clicks into place.

## Model numbers

Each model is specified using a part number in the following format:

**CL S 1 T RL LB W IR T1**

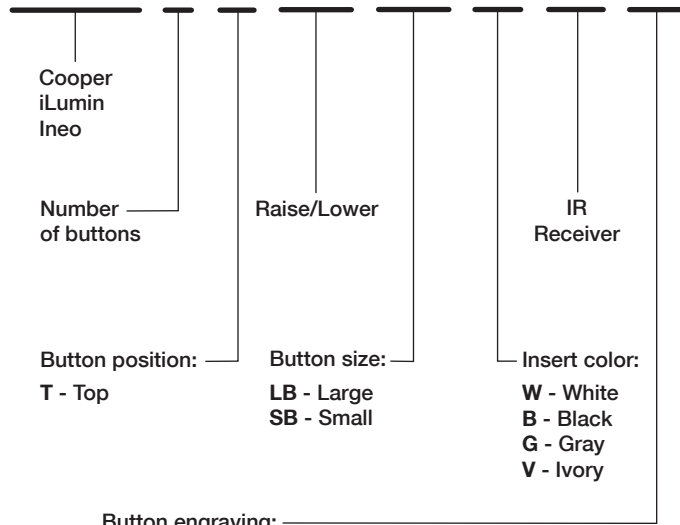

*Blank* Scene 1, Scene 2, etc.  
T1 Preset 1, Preset 2, etc.  
T2 General, Meeting, Seminar, Lecture  
T3 Lunch, Cocktails, Dinner, Special

## Ambient atmosphere requirements

Temperature 32°F to 104°F (0°C to +40°C)

Humidity 0 to 95% non-condensing

Document 73-889-00 IM8505 Iss.05

Cooper Controls  
Unit 4 Enterprise Center, Penshurst,  
Tonbridge, Kent, TN11 8BG, UK

**COOPER** Controls