

Rako RLED20+CC4 Installation, Programming and Operating Instructions

General

Rako RLED20+CC4 modules are three channel, constant current dimmers with a maximum rating of 20W per channel for use with 3 colour constant current LEDs. The module is designed to directly control LEDs with no additional drivers. The output current rating can be set to give 350mA, 500mA, or 700mA. They are designed to accept DC power from a suitably rated power supply up to a maximum of 48V DC. The RLED20+CC4 can be used with fittings with either separate or common positives.

Important

Do not connect directly to a 240V mains supply.

Installation should only be carried out by a competent electrician.

Never attempt to connect a Rako module or remove the terminal cover without first isolating the circuit at the fuse/MCB board.

The circuit supplying a Rako module should always be protected by either a 5A fuse or 6A MCB.

Mounting

Rako modules should be mounted in areas that are adequately ventilated, dry and outside of any enclosed metal casings that may interfere with the wireless signal. Wherever possible the mounting bracket should be used.

Modules should be mounted vertically or horizontally with the ventilation slots at the top.

Whilst Rako modules are designed to be completely maintenance free the units should be mounted in an accessible location should there be a fault or re-addressing of the unit be necessary (see 'Set-up and Addressing')

Loadings

The permissible loadings depend on several criteria keeping within the maxima for the unit of 20W per channel and a forward voltage of 45V. For the purposes of calculating the total forward voltage of an LED fitting refer to the manufacturer's data.

Channel Addressing

When giving the RLED20+CC4 a Rako channel address the next 2 channels are automatically assigned, sequentially from this point. For example, a module controlling an RGB fitting and addressed as channel 3 will control Red on channel 3, Green on channel 4 and Blue on channel 5.

Connections

Connect the RLED20+CC4 module according to the wiring diagram overleaf. Note the supply should be from a suitable DC power supply with an adequate power and voltage rating. The power supply should have a minimum voltage of 24V and a maximum of 48V and needs to give adequate forward voltage to drive the lamps connected. The internal voltage drop is approximately 3V giving an effective maximum output forward voltage of 45V.

As with all constant current LEDs fittings should be wired in series.

Use the header connector to select the required output current. The default with no header connected is 350mA.

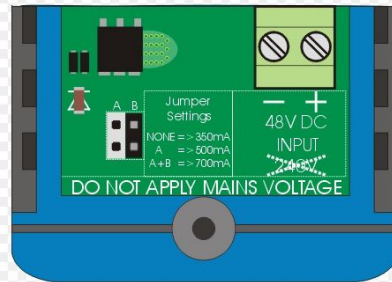

Fig. 1

In example Fig 1 above the current is set to 700mA

Do not use loop In/Out connections within the module. A junction box should be used if required.

Ensure the cable clamp bar securely clamps the cables and that the terminal cover is fitted before switching the supply on.

Initial Checks

When power is initially connected to the module the unit should switch the load ON. The load can then be manually switched using the clear button on top of the module.

The factory set address for both modules and transmitters is House 1 Room 4 (See Fig 2 for further information). A Rako wireless wall panel set as address House 1 Room 4 will control and dim the module.

Should the module not respond as above then further investigation should be made before proceeding further.

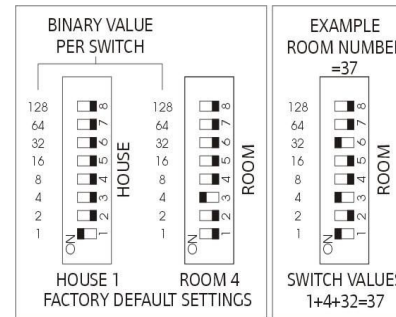

Fig.2

Set-Up and Addressing

RLED20+CC4 modules can be programmed manually or by using RASOFT programming software. For software programming refer to the appropriate programming guide supplied as a PDF with the programming interface (RA or RTC-Bridge etc.) or download from our website: www.rakocontrols.com.

For Manual addressing from the Keypad see the reverse of this sheet.

Notes on address switches

The address numbers are set using the switches on the back of a Rako transmitter. Binary coding is used and a diagrammatic explanation is given in Fig 2. It is not however necessary to understand binary just set the House switches to a different setting than the factory default and use a different combination of Room switch settings for each room or area to be controlled separately.

Power-Up Mode

With the factory address setting of House 1 an RLED20+CC4 will turn ON when power is applied. When the House address is changed the Power-Up mode becomes 'OFF' which is generally preferred, for instance if there is a power cut during a holiday.

Manual Operation

The clear button can be used as a manual On/Off switch.

Multiple Control Panels

If the module is to be controlled by two wall or hand-held transmitters it is only necessary to address the module to one of these transmitters. Set the other transmitters to the same House and Room address and they will transmit exactly the same message as the first transmitter and the module will respond accordingly.

LED functions

The internal LED behind the clear button will flicker when the module receives ANY Rako wireless message and is a useful diagnostic indicator. This function becomes inactive after 20 minutes to avoid nuisance light spill but can be re-activated by pressing the clear button.

If an RLED20+CC4 module has already been addressed to a wall-panel the internal LED will start to pulse as soon as that transmitter (or any other transmitter with the same address) is put into programming mode. The module can still be re-addressed in the normal way, for example when changing its Channel address within the same Room.

Colour Cycling

As a default setting the RLED20CC3 module will not dim from Fade Up/Down commands from a Rako transmitter but instead will start a colour cycle through the colours programmed for Scenes 1-4 when it receives a Fade Up command. A Fade Down command will stop the cycling

Care and Maintenance

A Rako module contains no user serviceable parts. Should for any reason you need to contact us please contact us via our website www.rakocontrols.com or by phoning our customer help line on 01634 226666.

Initial Addressing of a Rako Receiver Module

In the following procedure both the controllers (wallpanels and hand held remotes) and the receivers have an automatic time out after approximately 3 minutes when in programming or set-up mode. This feature avoids the possibility of either being left permanently in programming or set-up mode. This may cause confusion if either the controller or receiver times out before the procedure is complete. It is worth becoming familiar with the procedures before starting the addressing procedure. If at any time it is necessary to start again the controllers can be returned to normal mode by pressing the 'Off' button and the receivers by resetting the electrical supply.

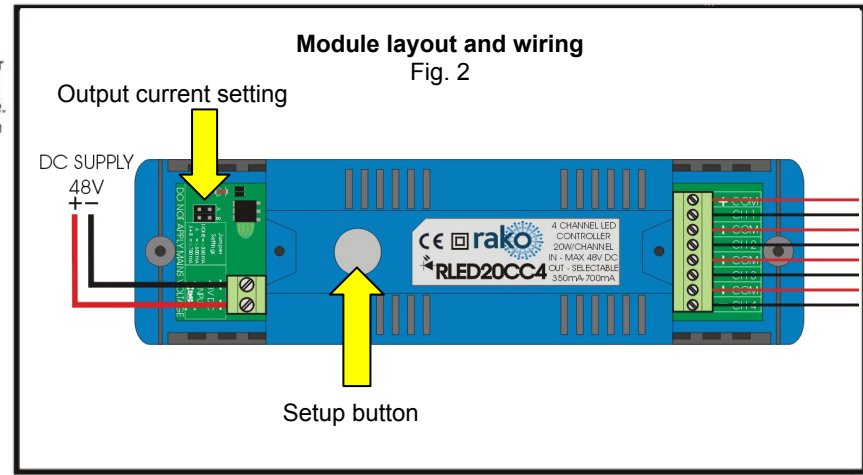

Step 1
Set address switches on controller

Pick a House address from 1-255 (keep same address for all panels in house)
Select Room addresses from 1-255 for each room (Room 0 is master house control)

Step 2
Put controller into programming mode by pressing and holding a scene button and both raise and lower buttons together. After 5 seconds the LED on the panel starts to flash. The panel is now in programming mode. Release the buttons

TIP
Press the scene button first

TABLE 1

Button	Action
1	Step up one channel and ident
2	Step down one channel and ident
3	Ident
4	No action
Off	Exit programming

Note:
A Rako panel will always enter programming mode at Channel 0. It is not possible to give a receiver an address of Channel 0 but this gives a consistent starting point.

Note:
When in programming mode the buttons have functions as detailed in table 1.

Step 3
Press button 1 once to step up one channel. If this is the desired channel i.e. Channel 1 (for the 1st receiver) then go to Step 4. If not, press button 1 again to step up to channel 2 (for the 2nd receiver), again to step to channel 3 etc, until the desired channel number is reached (maximum = 15). It is this channel number (along with the House and Room address) that is sent to the receiver in Step 5. If at any point it is necessary to step down a channel, press button 2 once.

Go to the receiver to be addressed

Step 4

Press the set-up button until the internal LED illuminates and keep the button pressed with the LED on until it starts to flash. Release the button. The module is now in set-up mode.

Note:
If a receiver is already addressed to a controller (for example a receiver is addressed to the controller but with the wrong channel number) then the internal LED will be flashing as soon as the panel is put into programming mode. It will still be possible to re-address this receiver as normal.

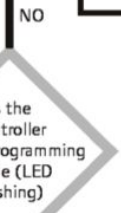

If some receivers are already addressed to a the wall panel then they will 'flash' their connected lamps as their channel number is reached during the stepping procedure, this allows the user to 'identify' which channel numbers are already taken. To add a new receiver to an existing installation step up through the channels until a channel number is reached where no receiver flashes a load, this is then an available channel. If at any point there is uncertainty as to whether a receiver actually flashed its load then button 3 will flash the load but without stepping up or down a channel. If all of the loads flash then this indicates that the current address is Channel 0.

Note: If it is not possible to see the connected lamps flashing when stepping through the channels it is possible to tell from the LEDs in the receivers which will momentarily go solid when their channel address is reached.

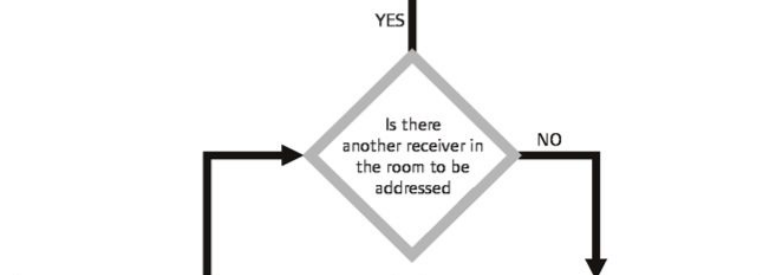

Press button 3 to send the ident of the channel selected in step 3. Receiver automatically returns to normal mode (blue LED goes out) while controller remains in programming mode (red LED keeps flashing)

Step 5

Press Off button to exit controller from programming mode

Step 6