

CoolLED

LED DRIVERS

CL DALI - GEN II

Up to 33W

270mA, 350mA, 450mA, 500mA, 600mA, 700mA, 900mA & 1050mA

CoolLED drivers provide a high performance solution for powering high-brightness LEDs from a mains supply.

DALI controlled drivers provide a digital alternative to standard 1-10V dimmable drivers and offer these key benefits:

Full Dimming Capabilities

Full DALI dimming support from 100% to 1% output current and the ability to turn completely off.

Individual and Group Control

Ability to control individual LED luminaires and simultaneous control of all or specified groups.

High Efficiency and Long Life

High Efficiency design ensures cool operation and long life. There is an extra benefit of a very low off power.

Compact Enclosure and Fast Assembly

Available in Flying Lead (A), Integral (B) and Remote Mount (C) versions. Remote types feature screwless cable clamps.

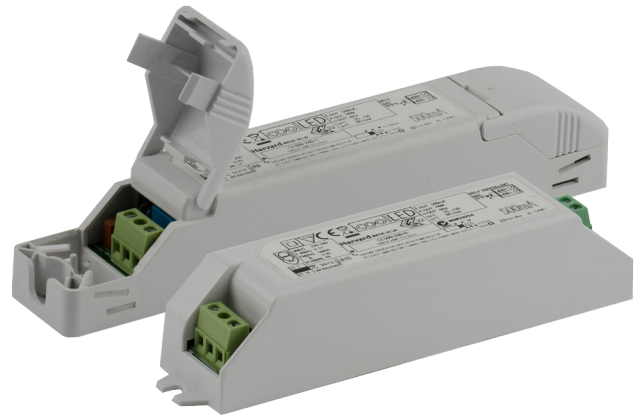

Product Description

- 220-240 Input voltage
- DALI control standard EN62386
- Fully-isolated, SELV output delivering up to 33W of power
- Power factor corrected (0.95)
- Isolated DALI interface
- Constant current output
- Self resetting thermal trip
- Double insulated (Class II)
- Up to 88% efficiency
- LED string fault reporting

DALI Support

- 100% - 1% or logarithmic linear dimming (selectable via DALI) and completely off
- 16 DALI groups
- 16 DALI scenes
- Lamp fault reporting checks on LED string volts
- Compliant with DALI control standards
- EN62386-101 EN62386-102 EN62386-207
- EN61347-1:2008+A1:2011+A2:2013,
- EN61347-2-13:2014, EN62384:2006+A1:2009



Wiring Diagram

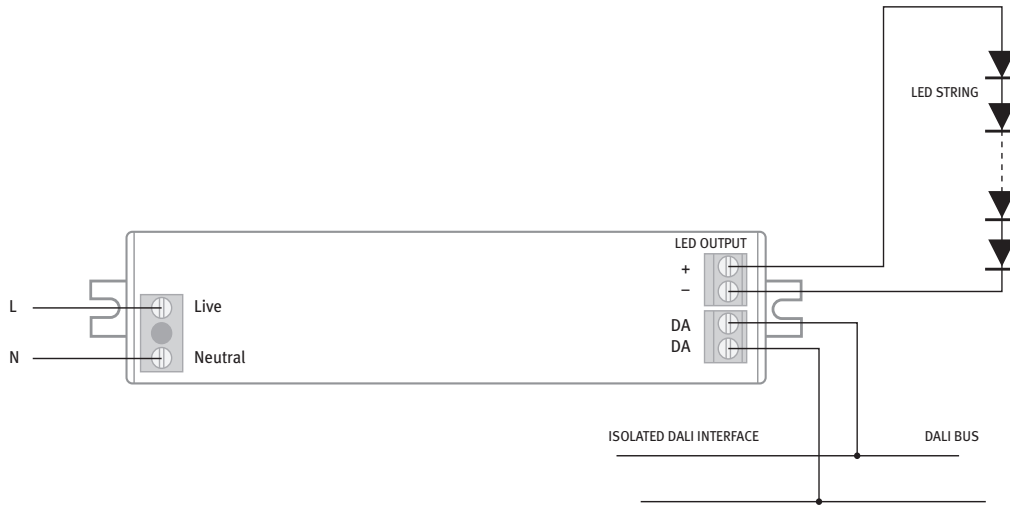

Technical Specification

Mains input voltage	220 to 240V ac Nominal
DC input voltage	175V - 275V
Mains frequency	0/50/60Hz*
Mains surge protection	4kV common-mode 2kV differential
Input-output isolation	3.75kV ac rms
Mains inrush current	45A peak decaying over 20us
Humidity	95% max non-condensing
Input power when output is off	<0.5W
Dimming range	100 - 1%
Terminal blocks	Rising clamp 10mm input pitch, 5mm output pitch
Enclosure	White polycarbonate UL94-V0 rated
Wire size	0.5mm to 1.5mm ²

Case Style	Dimensions	Weight	Box Quantity	IP Rating
B - Integral	150mm x 32mm x 32mm	120g	50	IP20
C - Cable clamps	180mm x 32mm x 32mm	120g	50	IP40

Tolerance: + or - 0.3mm

Operation

*Drivers are suitable for DC & AC operation at 0/50/60 Hz and compliant to EN50172. The operation is compliant to EN 60598-2-22 except with the 'high risk task lighting' applications.

SELV

DALI circuit has basic isolation to the SELV output.



Variants

Part number	Current	LED String Voltage	Max. Tc Temperature	Ambient Temperature Range	Thermal Trip (Self - resetting)	Output power range	Power factor at full load	Efficiency at full load
CL250D2-240-B/C	250mA (±5)	15V to 48V	75°C	-25 - 55°C	100°C	3.8 - 12W	0.91	83%
CL270D2-240-A/B/C	270mA (±5)	15V to 48V	75°C	-25 - 55°C	100°C	4.1 - 13W	0.91	83%
CL350D2-240-A/B/C	350mA (±5)	15V to 48V	80°C	-25 - 60°C	100°C	5.3 - 17W	0.91	86%
CL450D2-240-A/B/C	450mA (±5)	15V to 48V	85°C	-25 - 60°C	110°C	6.8 - 21.6W	0.92	87%
CL500D2-240-A/B/C	500mA (±5)	15V to 48V	85°C	-25 - 60°C	110°C	7.5 - 24W	0.92	87%
CL600D2-240-A/B/C	600mA (±5)	15V to 48V	80°C	-25 - 50°C	110°C	9.0 - 29W	0.95	88%
CL700D2-240-A/B/C	700mA (±5)	15V to 48V	85°C	-25 - 50°C	110°C	10.5 - 33W	0.96	88%
CL900D2-240-A/B/C	900mA (±5)	15V to 37V	80°C	-25 - 50°C	110°C	13.5 - 33W	0.96	87%
CL1050D2-240-A/B/C	1050mA (±5)	15V to 32V	85°C	-25 - 50°C	110°C	12.6 - 33W	0.94	87%

Dimensions

B Style

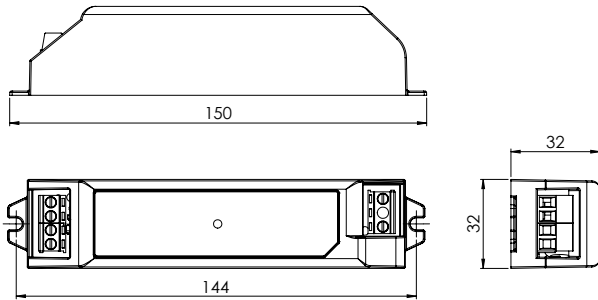

C Style

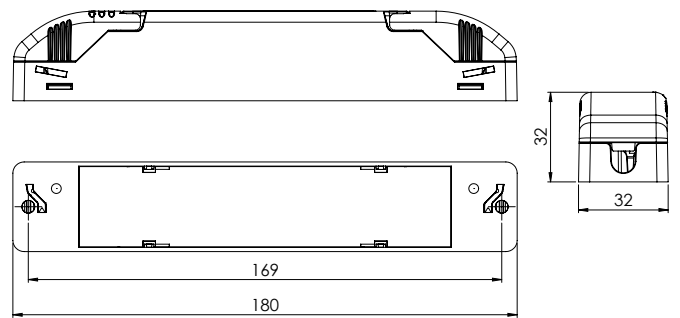

Compliance

Approval	Standards
ENEC (Europe)	EN61347-1:2008+A1:2011+A2:2013, EN61347-2-13:2014, EN62384:2006+A1:2009
CE (Europe)	LVD:2014/35/EU; EMC:2014/30/EU; RoHS:2011/65/EU; ECOD/2009/125/EC
CB (International)	IEC 61347-1:2007 (second edition)+A1:2010 +A2:2012; IEC 61347-2-13:2014 (second edition); IEC 62384:2006 (First edition)+A1:2009 BIS (India): IS15885 (Part 2/Sec 13)



CB
SCHEME



Harvard Power Systems Limited
1200 Century Way, Leeds, LS15 8ZA United Kingdom
Tel: +44 (0)113 880 5405



www.Harvardps.com

Efficiency vs Output Power over Dimming Range

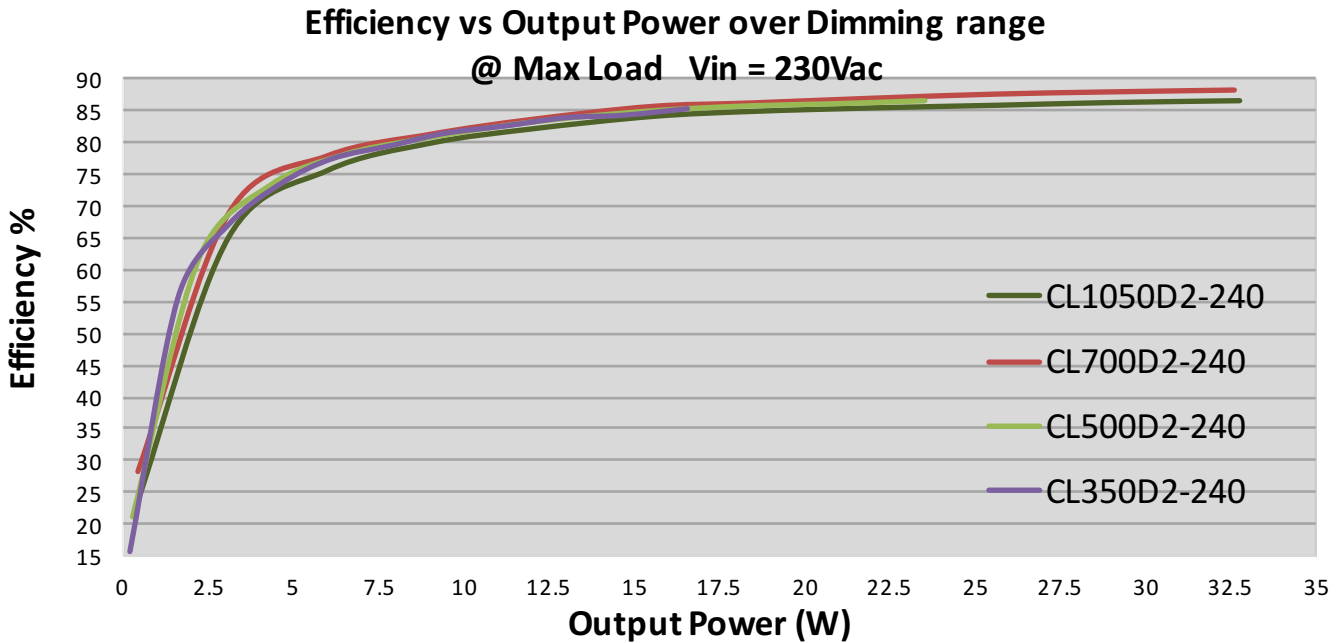

Power Factor vs Output Power over Dimming Range

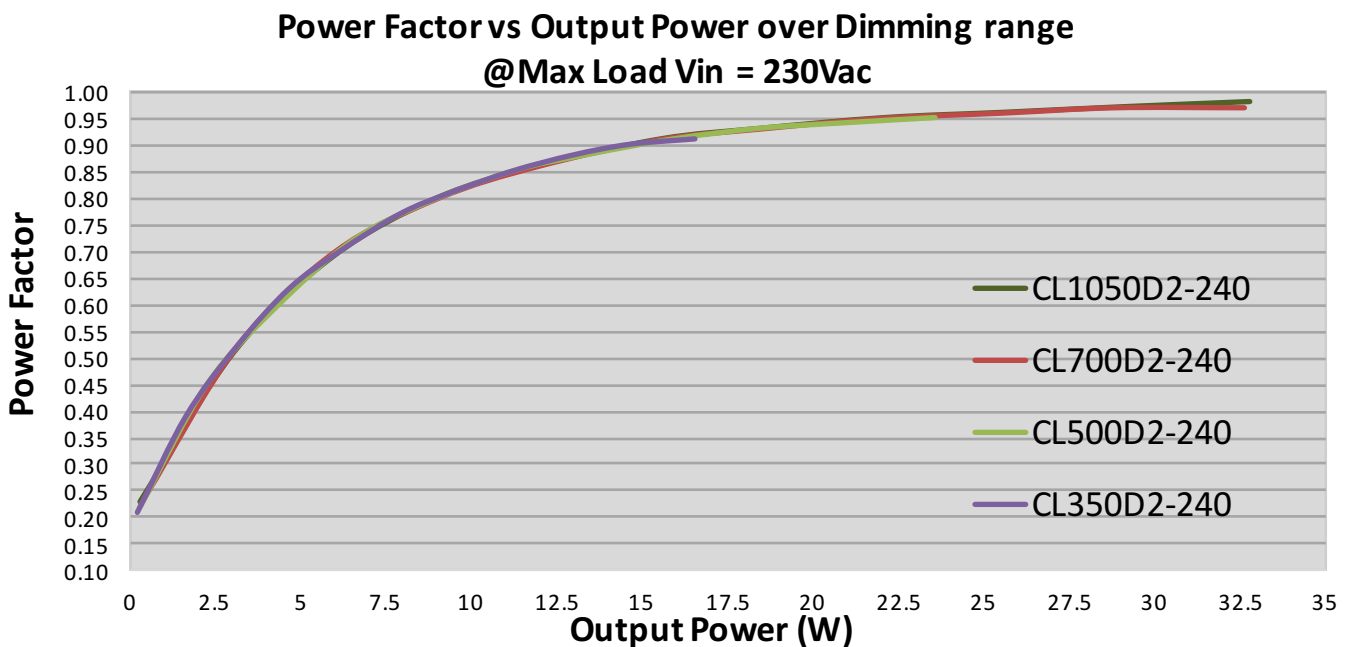

PLEASE NOTE

Information given in this datasheet is for illustration purposes only and subject to change without prior notice.

No liability is accepted for printing errors. Reference made to third party approval or certification may be subject to ongoing licence transfers and may not be fully implemented.

