

**PHILIPS**  
dynalite 

Sensors



# DUS90CS

Multifunction Sensor

Wall/ceiling mount 90° multifunction sensor

The DUS90CS is wall or ceiling mountable multifunction sensor that combines motion detection (PIR), infrared remote control reception (IR) and ambient light level detection (PE) into one device for applications such as offices, lecture theaters and homes.

Manufactured with an IP54 rating, the DUS90CS is resistant to dust and splashing, making it suitable for use in both indoor and sheltered outdoor areas.

# DUS90CS

## Wall/ceiling mount 90° multifunction sensor

- **Motion detection feature** — Detects the presence or absence of motion and adjusts lights accordingly. The sensor has a 90° scan pattern with flexible angle adjustment.
- **Ambient light level regulation** — In applications where it is necessary to maintain even lighting, the PE function reads ambient levels and adjusts artificial light accordingly.
- **Infrared receive capability** — Manually adjust light levels using a hand-held remote control, via the inbuilt IR receive sensor.
- **Daylight harvesting mode** — Delivers automatic energy savings.
- **Multiple mounting options** — and can be surface-mounted (wall/ceiling), or partially recessed (ceiling only) using the supplied junction box or butterfly clips.
- **IP54 rating** — Dust- and splash-resistant housing allows installation in a variety of indoor and outdoor applications..

---

## Dimensions

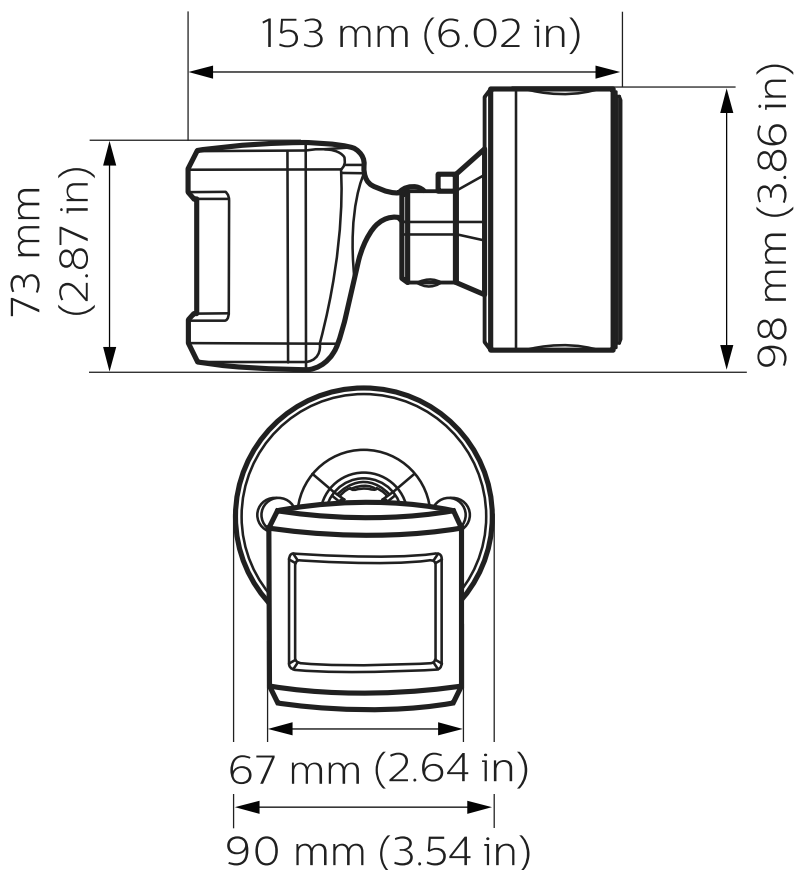

# Specifications

Due to continuous improvements and innovations, specifications may change without notice.



## DUS90CS Multifunction Sensor

### Electrical

Supply Type	DyNet
Supply Voltage	12/24 VDC
Supply Current	20 mA (max)
IEC Overvoltage Category	III

### Motion Detection (PIR)

Sensor	Dual element pyroelectric
Maximum Detection Range	20.6 m (67.6 ft)*
Scan Beam Angle	90°
Detection Area	See next page

### Light Detection (PE)

Lux Range	5-10,000 lux
-----------	--------------

### Control

Serial Ports	1 x RS-485
Supported Protocols	DyNet
User Input	Infrared (RC5 IR remote control)
Indicators	Red motion LED

\* Typical detection range at  $\leq 25^{\circ}\text{C}$  (77°F). Range is reduced at higher temperatures.

### Physical

Dimensions (H x W x D)	98 x 90 x 153 mm (3.86 x 3.54 x 6.02 in)
Packed Weight	0.26 kg (0.57 lb)
Construction	Polycarbonate plastic enclosure
Color	White (RAL9010)
Serial Ports	1 x screw terminal
Screw Terminal Conductor Size	2.5 mm <sup>2</sup> (#12 AWG) (max)

### Environment

Operating Temperature	-20° to 45°C ambient (-4° to 113°F)
Storage/Transport Temperature	-25° to 70°C ambient (-13° to 158°F)
Humidity	0 to 90% non-condensing
IEC Pollution Degree	II

### Compliance

Certification	CE, RCM, UL/cUL, FCC, ICES, UKCA, RoHS
IP Rating	IP54 (When installed as per manufacturer instructions)



## Detection Area

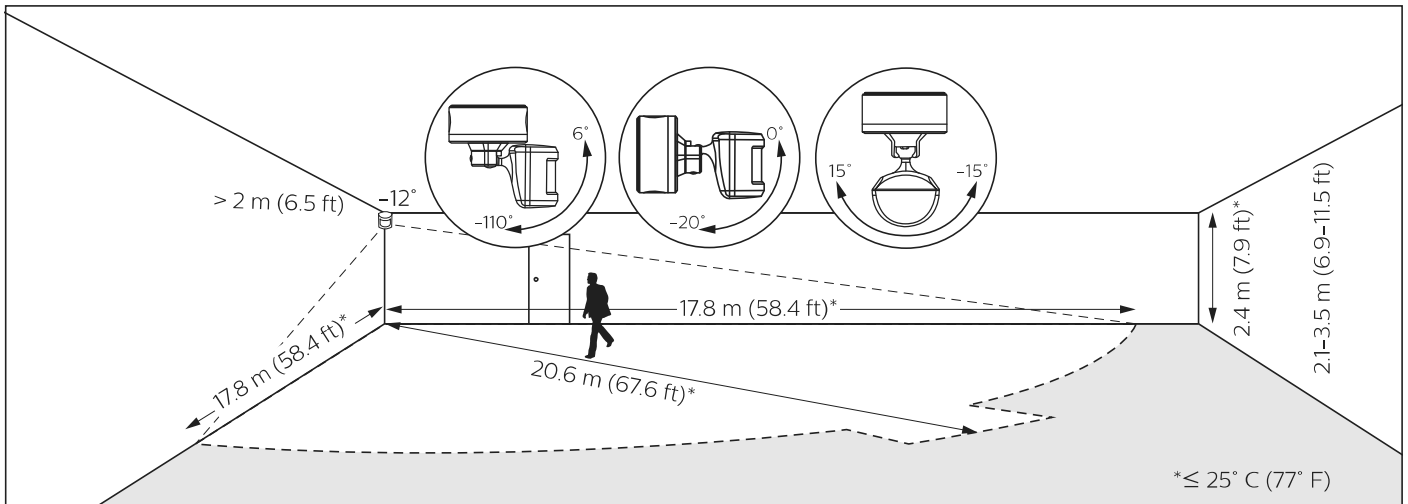

## Ordering Code

Product	Philips 12NC
DUS90CS	913703244209
Accessories	Philips 12NC
DINGUS-DUS-RJ12-DUAL (dual RJ12 connector - pack of 10)	913703064309
DINGUS-DUS-RJ45-DUAL (dual RJ45 connector - pack of 10)	913703064409
IRT9090/01 (commissioning & testing RC5 IR remote control)	913700359103



© 2023 Signify Holding. All rights reserved. Specifications are subject to change without notice. No representation or warranty as to the accuracy or completeness of the information included herein is given and any liability for any action in reliance thereon is disclaimed. Philips and the Philips Shield Emblem are registered trademarks of Koninklijke Philips N.V. All other trademarks are owned by Signify Holding or their respective owners.