

**basicDIM Wireless Passive module G2**

Casambi Ready wireless modules

**Product description**

- \_ Can be integrated in Casambi systems (Casambi Ready)
- \_ Wireless controllable with an Android / iOS smart device
- \_ No need for an external gateway device
- \_ Forms automatically a wireless communication network with up to 250 nodes <sup>①</sup>
- \_ Small form factor for luminaire installation
- \_ Digital output: Standalone DALI (compatible)
- \_ Supplied via DALI line
- \_ 4 independent push-button inputs
- \_ Easily implemented RGB and colour temperature controls
- \_ Device firmware can be updated over-the-air
- \_ 5 years guarantee (conditions at <https://www.tridonic.com/manufacture-guarantee-conditions>)

<sup>①</sup> Assignment of max. 4 single / group addresses, depending on the device profile.

**Website**

<http://www.tridonic.com/28003541>



**basicDIM Wireless Passive module G2**

Casambi Ready wireless modules

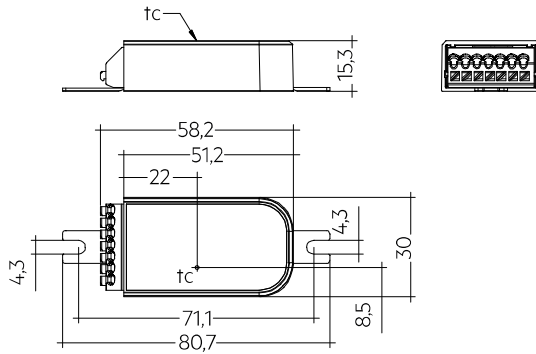
**Ordering data**

Type	Article number	Packaging, carton	Weight per pc.
basicDIM Wireless passive module G2	28003541	60 pc(s).	0.017 kg

**Technical data**

Supply voltage DC	9,5 – 22,5 V
Current consumption of DALI	4 mA (30 mA at start)
Max. DALI bus current	250 mA
Typ. power consumption on stand-by	< 0,09 W
Input	4 momentary-action switches
Max. cable length push button	5 m at 0,2-1,5 mm <sup>2</sup>
Radio transceiver operating frequencies	2,4 – 2,483 GHz
Max. output power radio transceiver (E.R.I.P.) <sup>②</sup>	< + 20 dBm
Output	DALI (compatible)
Number of DALI addresses <sup>①</sup>	4
Ambient temperature $t_a$	-20 ... +70 °C
Max. casing temperature $t_c$	75 °C
Storage temperature $t_s$	-25 ... +75 °C
Lifetime	up to 50,000 h
Guarantee (conditions at <a href="http://www.tridonic.com">www.tridonic.com</a> )	5 Year(s)
Dimensions L x W x H <sup>③</sup>	80,7 x 30 x 15,3 mm
Type of protection	IP20

**Approval marks****Standards**

EN 55015, EN 55022, EN 55032, EN 61347-1, EN 61347-2-11, EN 61547, ETSI EN 300 328, ETSI EN 301 489-1, ETSI EN 301 489-17

① Assignment of max. 4 single / group addresses, depending on the device profile.

② E.I.R.P.: Equivalent Isotropically Radiated Power.

③ Screw fixings can be removed.

basicDIM Wireless User Interface

Accessory



**Product description**

- \_ Can be integrated in Casambi systems (Casambi Ready)
- \_ Battery powered, wireless wall switch
- \_ Forms automatically a wireless communication network with up to 250 nodes <sup>①</sup>
- \_ Controls all types of basicDIM Wireless devices
- \_ 4 scenes
- \_ Dim up / down
- \_ Colour temperature control
- \_ 5 years guarantee (conditions at <https://www.tridonic.com/manufacture-guarantee-conditions>)

<sup>①</sup> Depends on production number, see data sheet basicDIM Wireless User Interface.

**Website**

<http://www.tridonic.com/28002213>

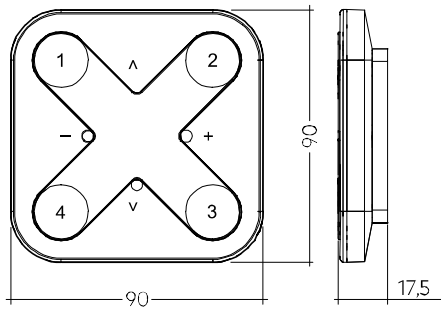

**Ordering data**

Type	Article number	Colour	Packaging, carton	Weight per pc.
basicDIM Wireless User Interface	28002213	Black	50 pc(s).	0.078 kg
basicDIM Wireless User Interface white	28002420	White	50 pc(s).	0.078 kg

**Approval marks**



## 1. Standards

EN 55015  
 EN 55022  
 EN 55032  
 EN 61347-1  
 EN 61347-2-11  
 EN 61547  
 ETSI EN 300 328  
 ETSI EN 301 489-1  
 ETSI EN 301 489-17

### 1.1 Glow wire test

according to EN 61347-2-11 with increased temperature of 850 °C passed.

## 2. Common

### 2.1 Description

The basicDIM Wireless passive module G2 is a bluetooth DALI controller with 4 freely configurable push-button inputs. The module is powered by the DALI bus, no additional mains supply is needed.

The module can be connected to one or more DALI drivers also in combination with one DALI XC G3 or Tridonic DALI MSensor for easy integration of daylight control and motion detection.

The basicDIM Wireless passive module G2 can also be used as a DALI-Gateway to extend an already existing wired DALI installation with wireless luminaires, sensors and push-buttons. DALI commands can be passed from the bluetooth network through the DALI-Gateway onto the physical DALI-Line and be processed by an DALI-2 application controller.

In both cases, the controlling capabilities and restraints of the used device profiles has to be checked before.

All basicDIM Wireless devices can be controlled with the Tridonic app "4remote BT". The app can be downloaded free of charge from the Apple App Store and Google Play Store.

### 2.2 Operation

The basicDIM Wireless passive module G2 is fully compatible with networks which support up to 250 nodes (Evolution networks). If the module is used with different types of basicDIM Wireless devices in an Evolution network, their compatibility has to be checked before.

Multiple devices automatically form a mesh network that can be controlled from any point. These networks communicate wirelessly directly with the smartphone or tablet. Therefore, an external gateway or wireless LAN network is not needed.

basicDIM Wireless devices have an integrated 2.4 GHz antenna. For optimum RF-performance, a special attention will have to be given when the device is integrated into a luminaire. See chapter 5.5 Placement for further instructions.

basicDIM Wireless devices can be used very flexible for different use cases. The operating modes (profiles) can be changed in the 4remote BT app.

## 3. Thermal details and lifetime

### 3.1 Expected lifetime

#### Expected lifetime

Type	ta	75 °C	70 °C	60 °C
basicDIM Wireless passive module G2	tc	75 °C	70 °C	60 °C
	Lifetime	38,000 h	50,000 h	100,000 h

The device is designed for a lifetime stated above under reference conditions and with a failure probability of less than 10 %.

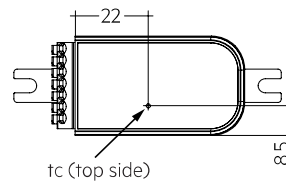

## 4. Interfaces / communication

### 4.1 DALI output

The basicDIM Wireless passive module G2 draws its operating power directly from the DALI bus. For this reason, it is important to make sure that the DALI bus is externally powered.

If the module is connected to a DALI device without an internal power supply, an external power supply must be used.

### 4.2 Push-button input

Independent push-buttons can be connected to each of the four input terminals. The „COM“ terminal is shared by all four push-buttons. The max. cable length between push-button and terminal is 5 m.

With the push-button interface, it is possible to control e.g. individual luminaires of a basicDIM Wireless network or even the whole network.

Please make sure that the correct profile has been uploaded to the basicDIM Wireless device, otherwise push-button presses cannot be recognized and also configuration of the inputs in the 4remote BT app is not available.

## 5. Installation / wiring

### 5.1 Wiring diagram with external PS

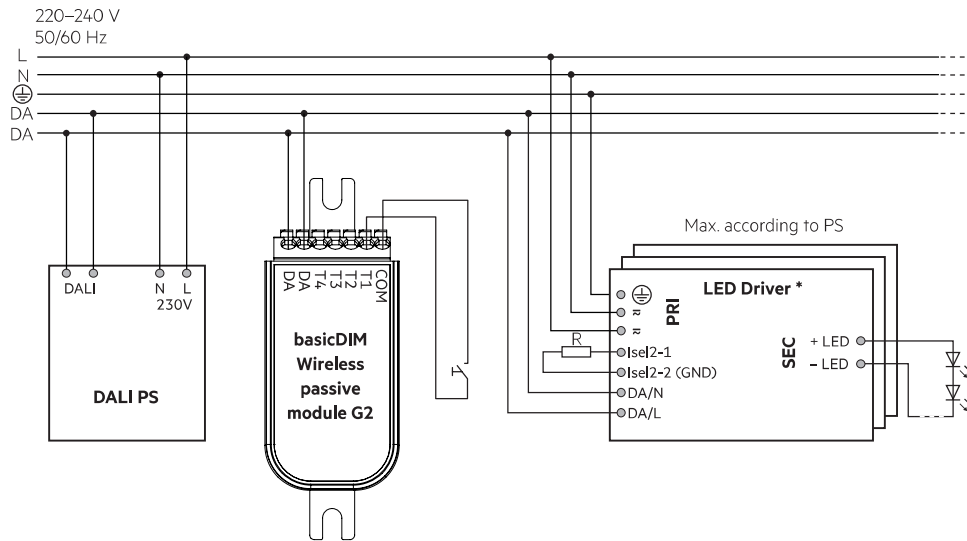

\* Max. 4 DALI single / group addresses (A0 ... A3 / G0 ... G3) controllable, depending on the device profile of the basicDIM Wireless module.  
The rest of the connected drivers can be controlled via broadcast – depending on the device profile.

### 5.2 Wiring diagram with integrated DALI PS

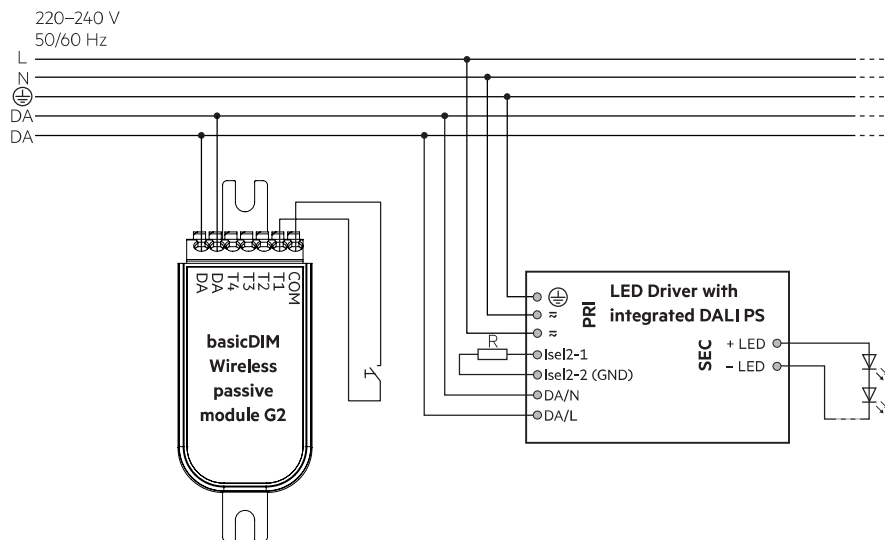

### 5.3 Wiring diagram with DALI MSensor and DALI PS

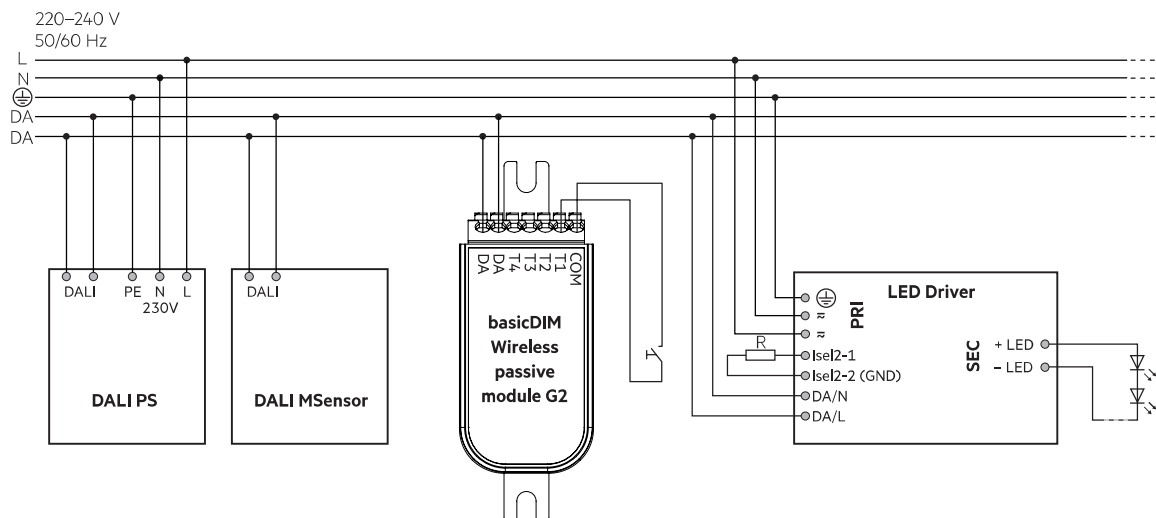

#### 5.4 Wiring type and cross section

For wiring use stranded wire with ferrules or solid wire from 0.2–1.5 mm<sup>2</sup> (16–24 AWG).

Strip 8.5–9.5 mm of insulation from the cables to ensure perfect operation of the push-wire terminals.

Use one wire for each terminal connector only.

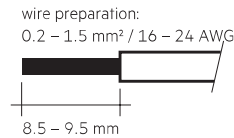

#### 5.5 Placement

basicDIM Wireless devices have an integrated antenna for easy integration. In order to maximize the range in every direction some design guidelines should be taken into consideration when mounting the device.

The antenna is located at the end of the enclosure.

When the device is mounted on a metal plate (e.g. frame of a luminaire), it may efficiently block the radio frequency signal. In this case, a cut-out underneath the antenna may be needed for the RF signal to exit the structure. The cut-out area should be as large as possible. Also the device should be placed as far away from any vertical metal structures as possible.



■ Antenna location



The range of the communication signal is depending on the environment e.g. luminaire, construction of the building, furnitures or humans and needs to be tested and approved in the installation.



To ensure a good radio connection, do not cover the basicDIM Wireless module completely with metal!

#### 5.6 Installation note

Max. torque at screw fixing: 0.4 Nm / M3.

## 6. Miscellaneous

### 6.1 Disposal of equipment



Return old devices in accordance with the WEEE directive to suitable recycling facilities.

### 6.2 Conditions of use and storage

Humidity: 5 % up to max. 85 %, not condensed

Storage temperature: -25 °C up to max. +75 °C

The devices have to be acclimatised to the specified temperature range (ta) before they can be operated.

### 6.3 Additional information

The Bluetooth® word mark and logos are registered trademarks owned by the Bluetooth SIG, Inc. and any use of such marks by Zumtobel Group AG is under license.

Tridonic GmbH & Co. KG is a subsidiary of Zumtobel Group AG.

Additional technical information at [www.tridonic.com](http://www.tridonic.com) → Technical Data

Lifetime declarations are informative and represent no warranty claim. No warranty if device was opened.