

CoolLED

LED DRIVERS

CL Standard

## Up to 33W

**270mA, 350mA, 400mA, 500mA, 600mA,  
700mA, 800mA, 1000mA & 1050mA**

CoolLED drivers provide a high performance solution for powering high-brightness LEDs from a mains supply.

The power factor corrected, class II driver has fully isolated, SELV output delivering up to 33W of power.

All CoolLED Drivers have a high efficiency design, which ensures cool operation and long life. The compact enclosure is available in Remote with Flying Leads (A), Integral (B) and Remote (C) versions. Remote types feature screwless cable clamps. (AB) Conformal Coating.

CoolLED Drivers are open and short-circuit protected and have a self resetting over temperature trip.

Consult the sales office for versions where the current level can be set by external switch or presence detector. These drivers include a "soft dim" feature to avoid sudden steps in LED brightness.



## Product Description

- 220-240 Input voltage
- Combined forward voltage of up to 48V
- Power factor corrected (0.98)
- Constant current output
- Self resetting thermal trip
- Double insulated (Class II)
- Screwless cable clamps for fast assembly (Remote Style)
- Up to 88% efficiency
- Surge protection up to 4kV
- SELV isolation to 3kV
- Dimmable versions available (consult sales team for details)

## Wiring diagram

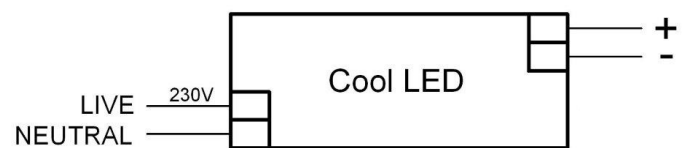

## Harvard Technology Ltd.

EU - Tyler Close, Normanton, Wakefield, WF6 1RL, UK Tel: +44 (0)113 383 1000 Fax: +44 (0)113 383 1010

USA - 9171 Towne Centre Drive, Suite #330, San Diego, California, 92122 Tel: (858) 882 - 3844

[www.HarvardTechnology.com](http://www.HarvardTechnology.com)



## Technical Specification

Mains input voltage	220 to 240V ac RMS Nominal
DC input voltage	190 - 265V DC
Mains frequency	0/50/60Hz
Mains surge protection	4kV common-mode 2kV differential
Input-output isolation	3kV ac rms
Mains inrush current	45A peak decaying over 20us
Humidity	95% max non-condensing
Thermal trip	110°C - internal self-resetting
Ambient temperature range	-25°C to 50°C
Maximum Tc temperature	80°C
Terminal blocks	Rising clamp 10mm input pitch, 5mm output pitch
Enclosure	White polycarbonate UL94-V0 rated
Wire size	0.5mm to 1.5mm <sup>2</sup>

Case Style	Dimensions	Weight	Box Quantity
A - Flying leads	151mm x 32.5mm x 32mm	132g or 260g (potted)	50
AB - Hybrid	150mm x 32mm x 32mm	126g	50
B - Integral	150mm x 32mm x 32mm	115g	50
C - Cable clamps	180mm x 32mm x 32mm	130g	50

Tolerance: + or - 0.3mm

## Variants

Part number	Current	LED String Voltage	Current ripple @ Full load	Output power range	Power factor @ Full load	Efficiency @ Full load
CL270-240-A/B/C	270mA (±5)	9V to 58V	20%	2.43 - 15W	0.95	86%
CL350-240-A/B/C/AB	350mA (±5)	9V to 48V	17.5%	3.15 - 17W	0.95	88%
CL400-240-A/B/C	400mA (±5)	9V to 56V	28.8%	3.6 - 22W	0.95	88%
CL500-240-A/B/C/AB	500mA (±5)	9V to 48V	20.7%	4.5 - 24W	0.95	88%
CL600-240-A/B/C	600mA (±5)	9V to 48V	21.7%	5.4 - 29W	0.95	88%
CL700-240-A/B/C/AB	700mA (±5)	9V to 48V	24.1%	6.3 - 33W	0.95	88%
CL800-240-B/C	800mA (±5)	9V to 42V	25.6%	7.2 - 33W	0.95	87%
CL1000-240-A/B/C/AB	1000mA (±5)	9V to 33V	31.5%	9 - 33W	0.95	86%
CL1050-240-A/B/C	1050mA (±5)	9V to 31V	33.6%	9.45 - 33W	0.95	86%

All AB style products are conformal coated



**Harvard Technology Ltd.**

EU - Tyler Close, Normanton, Wakefield, WF6 1RL, UK Tel: +44 (0)113 383 1000 Fax: +44 (0)113 383 1010

USA - 9171 Towne Centre Drive, Suite #330, San Diego, California, 92122 Tel: (858) 882 - 3844

[www.HarvardTechnology.com](http://www.HarvardTechnology.com)



## Compliance

Approval	Standards
ENEC (Europe)	EN61347-1:2008+A1:2011 +A2:2013; EN61347-2-13:2014; EN62384:2006+A1:2009
CE (Europe)	LVD:2014/35/EU; EMC:2014/30/EU; RoHS:2011/65/EU; ECOD/2009/125/EC
CB (International)	IEC 61347-1:2007 (second edition)+A1:2010 +A2:2012; IEC61347-2-13:2014 (second edition) IEC 62384:2006 (first edition) +A1:2009
BIS (India)	IS 15885 (Part 2/Sec.13)



CB  
Scheme



## Dimensions

## A Style

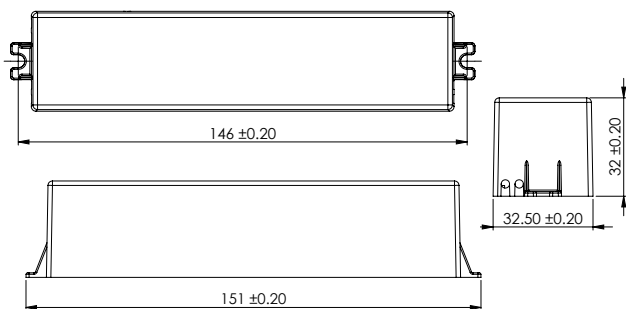

## AB Style

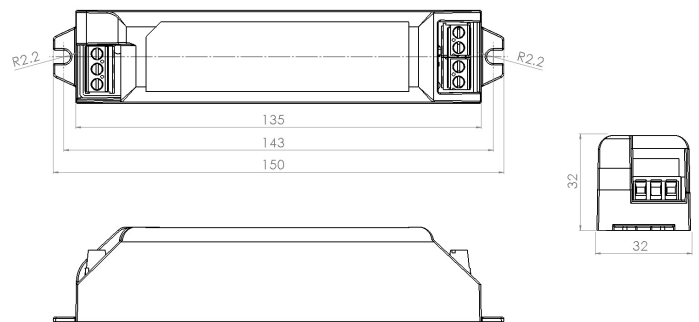

## B Style

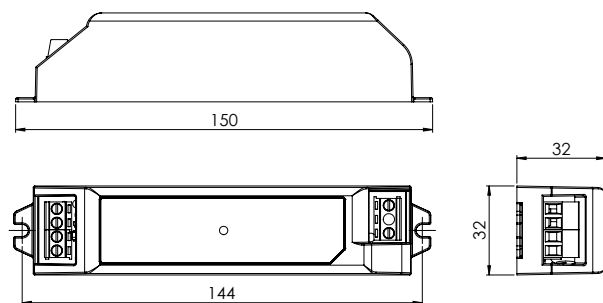

## C Style

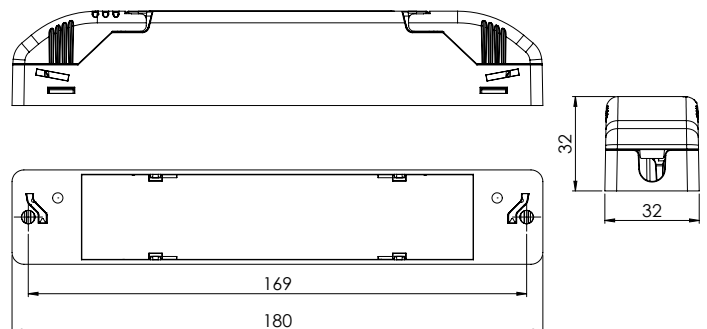

**Harvard Technology Ltd.**

EU - Tyler Close, Normanton, Wakefield, WF6 1RL, UK Tel: +44 (0)113 383 1000 Fax: +44 (0)113 383 1010

USA - 9171 Towne Centre Drive, Suite #330, San Diego, California, 92122 Tel: (858) 882 - 3844

[www.HarvardTechnology.com](http://www.HarvardTechnology.com)



### Efficiency Vs Output Power

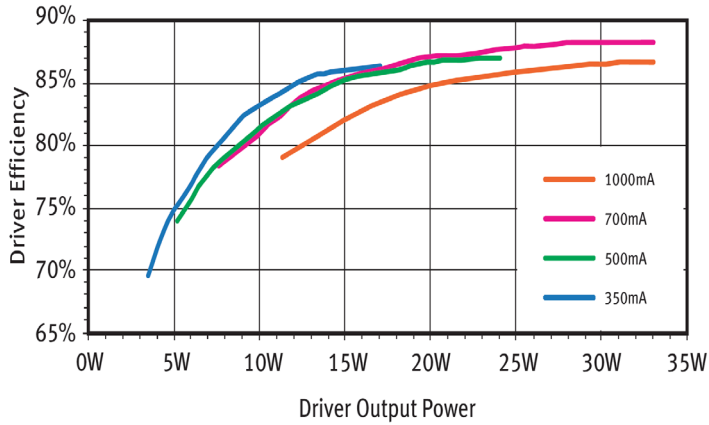

### Power Factor Vs Output Power

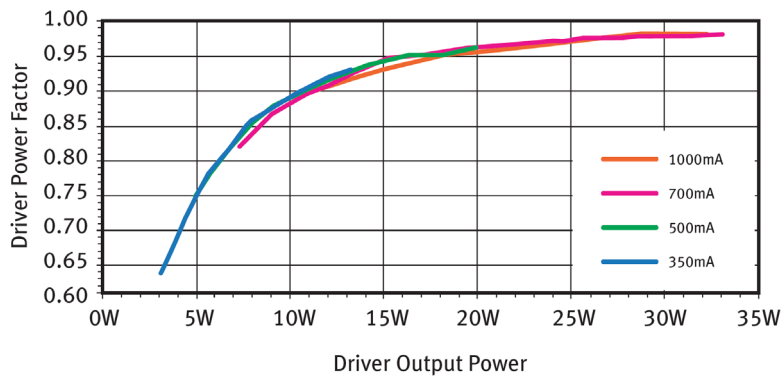

NB. Low power driver available at 350mA & 700mA to improve efficiency for output loading of 10W and below.



**Harvard Technology Ltd.**

EU - Tyler Close, Normanton, Wakefield, WF6 1RL, UK Tel: +44 (0)113 383 1000 Fax: +44 (0)113 383 1010

USA - 9171 Towne Centre Drive, Suite #330, San Diego, California, 92122 Tel: (858) 882 - 3844

[www.HarvardTechnology.com](http://www.HarvardTechnology.com)

