

DALI PCD 1-380 one4all G3

DALI actuator



Product description

- _ Digital leading-edge and trailing-edge phase dimmer
- _ Total connected load: 1 – 380 VA
- _ one4all input: DALI, DSI, switchDIM and corridorFUNCTION input
- _ Zero cross switching supported
- _ 1 dimmed phase (output)
- _ With automatic load detection
- _ Surface-mounted casing
- _ Suitable for operation with LED retrofit bulbs
- _ 5 years guarantee (conditions at <https://www.tridonic.com/manufacture-guarantee-conditions>)

Website

<http://www.tridonic.com/28004625>



DALI PCD 1-380 one4all G3

DALI actuator

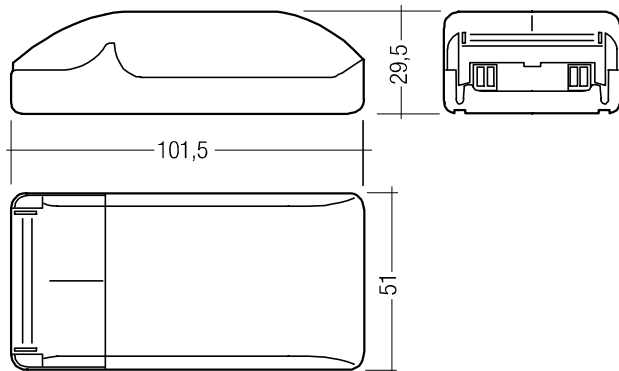

Ordering data

Type	Article number	Packaging, carton	Weight per pc.
DALI-PCD 1-380 one4all G3	28004625	25 pc(s).	0.085 kg

Technical data

Rated supply voltage	220 – 240 V
Mains frequency	50 / 60 Hz
Connected load	1 – 380 VA
Power loss	0.6 W (1.8 W at full load)
Ambient temperature t_a	0 ... +50 °C
Storage temperature t_s	-20 ... +50 °C
Humidity	0 ... 95 %
Type of protection	IP20
Lifetime	up to 50,000 h
Guarantee (conditions at www.tridonic.com)	5 Year(s)
Dimensions L x W x H	101.5 x 51 x 29.5 mm

Approval marks



Standards

EN 61347-1, EN 61347-2-11, EN 60669-1, EN 60669-2-1, EN 50428, EN 62386-101, EN 62386-102, EN 62386-205

Specific technical data

Type	Inputs			Outputs			Terminals
	Input, DALI / DSI control input / switchDIM and corridorFUNCTION N	Current draw	Number of DALI addresses	Dimmed phase	Control range, DSI	Control range, DALI	
DALI-PCD 1-380 one4all G3	1	2 mA from DALI	1	1	1 – 100 %	0.1 – 100 %	0.5 – 1.5 mm ²

1. Standards

EN 61347-1
 EN 61347-2-11
 EN 60669-1
 EN 60669-2-1
 EN 50428
 EN 62386-101 Ed. 2
 EN 62386-102 Ed. 2
 EN 62386-205

2. Common

Phase dimmers with automatic load detection, leading-edge or trailing-edge.
 Controlled via switches (switchDIM and corridorFUNCTION) or a DALI/DSI signal.
 Total connected load: 1–380 VA

2.1 Area of application

Digital phase dimmers enable low-voltage tungsten-halogen lamps, in conjunction with electronic or magnetic transformers, and ohmic light sources (incandescent lamps) with a total output of 1 to 380 VA to be dimmed.
 Control is either via a DALI/DSI signal or directly connected switches (switchDIM and corridorFUNCTION).
 The digital phase dimmer is compatible with LED retrofit lamps. Because of the variety of different LED Retrofit lamps it is recommended to test the operation before installation.
 LV halogen LED retrofit lamps that are operated by an electronic or magnetic transformer are also compatible.

3. Installation

3.1 Wiring

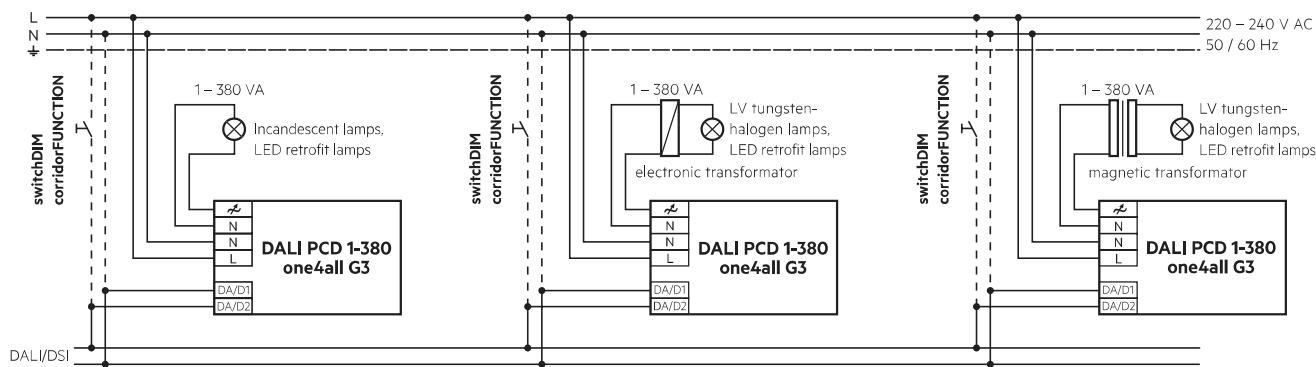

Mixed loads (capacitative, inductive and ohmic) may be used.¹⁾

¹⁾ Different loads require different control signals by the dimmer. If various loads are operated simultaneously at the dimmer, e.g. electronic transformers, magnetic transformers, LED retrofit lamps, etc., the dimming signal will focus on the most dominant load. As a result, the other loads may be operated by wrong control signals, which will result in improper dimming. In this case, a decrease in the service life of the loads installed cannot be excluded either. It is therefore recommended to avoid controlling different loads simultaneously by the same dimmer.



Information on minimum dimming level

The PCD 1-380 supports in general a min. dimming level of 1% for DSI and 0.1% for DALI. But not every load supports such low levels. For that reason the minimum dimming level is not a static value and is calculated for every load new.

3.2 Wiring type and cross section

For wiring use stranded wire with ferrules or solid wire.
 For perfect function of the cage clamp terminals the strip length should be 4 – 5 mm for the input terminal.
 The max. torque at the clamping screw (M3) is 0.2 Nm.

Side D2

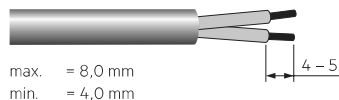

Side D1

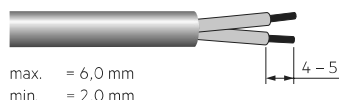

To get a proper working strain relief it is recommended that the cable jacket diameter of the side D2 is 2 mm bigger than the diameter of the side D1.
 (This can vary if the used cable jacket material varies from side D2 to D1 in pinching property).

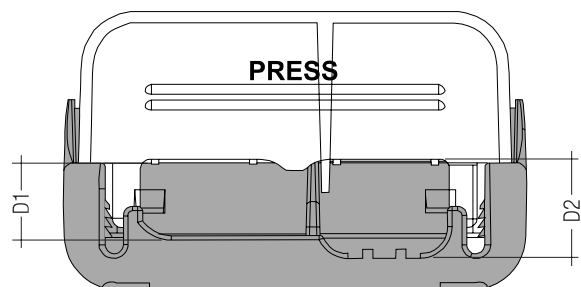

- DALI signals are not SELV. Therefore the same procedures should be applied as working with mains voltage.
- Only plastic screws may be used for fastening.
- Individual DALI circuits must not exceed 250 mA (depends on the used DALI Powersupply).
- The maximum cable length of the DALI signal wires must not exceed 300m or drop more than 2V on the signal line voltage.



Control terminals marked „Risk of electric shock“ are not safe to touch.
 Circuits connected to any FELV control terminal shall be insulated from the LV supply voltage of the control gear and any terminals connected to the FELV circuit shall be protected against accidental contact.



There is a risk of electric shock when touching these terminals in case of failure.
 Note: In some countries basic insulated control terminals are to be marked with this symbol.

3.3 Fixing conditions

Dry, acidfree, oilfree, fatfree. It is not allowed to exceed the maximum ambient temperature (t_a) stated on the device. Minimum distances stated below are recommendations and depend on the actual luminaire.
 Is not suitable for fixing in corner.

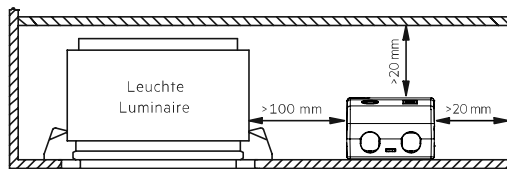

Device not suitable for covering with thermally insulating material according to IEC 60598-1 Ed.9

4. Functions

4.1 Control input (DA/N, DA/L)

Digital DALI signal or switchDIM can be wired on the same terminals (DA/N and DA/L).

The control input is non-polar for digital control signals (DALI, DSI).
 The control signal is not SELV. Control cable has to be installed in accordance to the requirements of low voltage installations.
 Different functions depending on each module.

4.2 corridorFUNCTION

The corridorFUNCTION can be programmed in two different ways.
 To program the corridorFUNCTION by means of software a DALI-USB interface is needed in combination with a DALI PS.
 The software can be the masterCONFIGURATOR.
 To activate the corridorFUNCTION without using software a voltage of 230 V has to be applied for five minutes at the switchDIM connection.
 The unit will then switch automatically to the corridorFUNCTION.



If the corridorFUNCTION is wrongly activated in a switchDIM system (for example a switch is used instead of pushbutton), there is the option of installing a pushbutton and deactivating the corridorFUNCTION mode by five short pushes of the button within three seconds.

switchDIM and corridorFUNCTION are very simple tools for controlling gears with conventional pushbuttons or motion sensors.
 To ensure correct operation a sinusoidal mains voltage with a frequency of 50 or 60 Hz is required at the control input.
 Special attention must be paid to achieving clear zero crossings.
 Serious mains faults may impair the operation of switchDIM and corridorFUNCTION.

4.3 switchDIM

When a new unit is installed in an existing system or when the system is first put into operation the individual units are not synchronised. This means that some units will be at status on and some at status off. Pressing the switch briefly will change the status; units previously on will be switched off, but the rest will be switched on. By pressing the switch for longer than 10 seconds all the units will be synchronised to the same status. The synchronisation process is completed when all the lamps have assumed the same light value (50 %).

The same synchronisation process may also be necessary during normal operation if an individual unit becomes unsynchronised because of an incorrect switching operation.

switchDIM is a very simple tool for controlling ballasts with conventional momentary-action switches or motion sensors.

To ensure correct operation a sinusoidal mains voltage with a frequency of 50 or 60 Hz is required at the control input.

Special attention must be paid to achieving clear zero crossings.

Serious mains faults may impair the operation of switchDIM.

4.4 Automatic load measurement

In default setting the PCD does an automatic load measurement after every mains interruption. This guaranties ideal load control. Disable the automatic load measurement via the programming of the Physical Minimum Level (PML) with the software masterCONFIGURATOR. If the Power On Level (POL) is set to 0, the load measurement starts after a DALI command > 0 is send to the PCD and not directly after mains is switched back on.

4.5 Display of load factor

After every automatic load measurement, the amount of possible connectable loads will be indicated for 2 minutes by the LED located on the device, between the DALI and mains terminals.

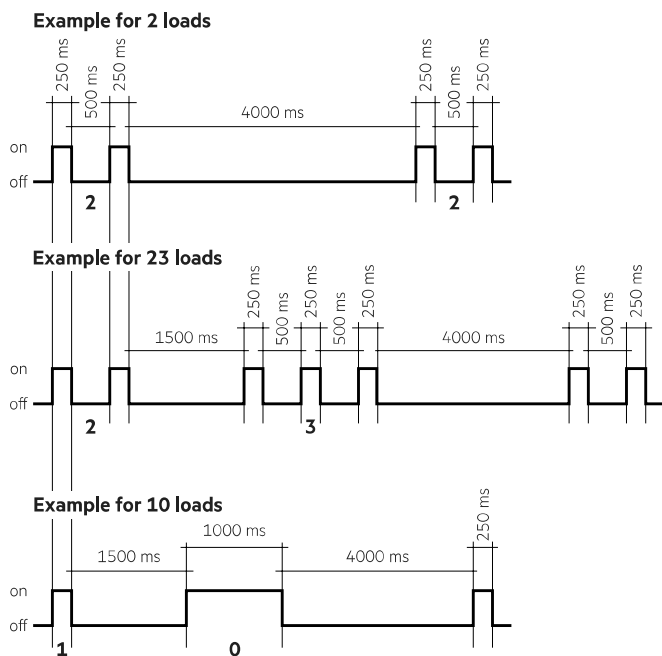

Values up to 99 can be displayed.
 0 will be indicated with the LED switched on for 1,000 ms.
 1 – 9 will be indicated with the LED blinking 250 ms on, 500 ms off.
 Break between digits = 1,500 ms.
 Break between full numbers = 4,000 ms.

4.6 Reset switch

The reset switch is located between the DALI and Mains terminals. By operating the reset switch a new load measurement can be executed. In addition in the second phase the PCD can be reset to factory settings. The automatic load measurement is active in the factory settings.

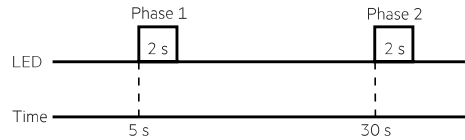

Release switch in Phase 1 = Load measurement will be executed, the PHM will be changed accordingly to the measurement result. Automatic load measurement will be deactivated.

Release switch in Phase 2 = The PCD will be reset to factory settings. Automatic load measurement will be activated again and executed after every mains interruption.

Important the switch has to be released within the 2 second window in which the indication LED is switched on.

The execution of Phase 1 and 2 will be visualized by a sequence of the indication LED. The sequence will start 5 seconds after the phase during witch the switch was released.

Example triggering Phase 1:

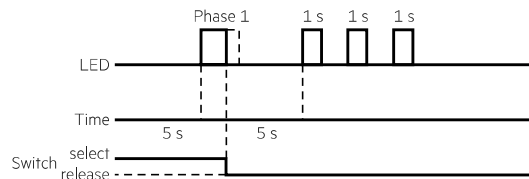

5. Miscellaneous

5.1 Disposal



According to the WEEE directive return old equipment at appropriate collection facilities.

5.2 Additional information

Additional technical information at www.tridonic.com → Technical Data

Guarantee conditions at www.tridonic.com → Services

Lifetime declarations are informative and represent no warranty claim. No warranty if device was opened.